

Climbing gym

# GEAR

# GUIDE

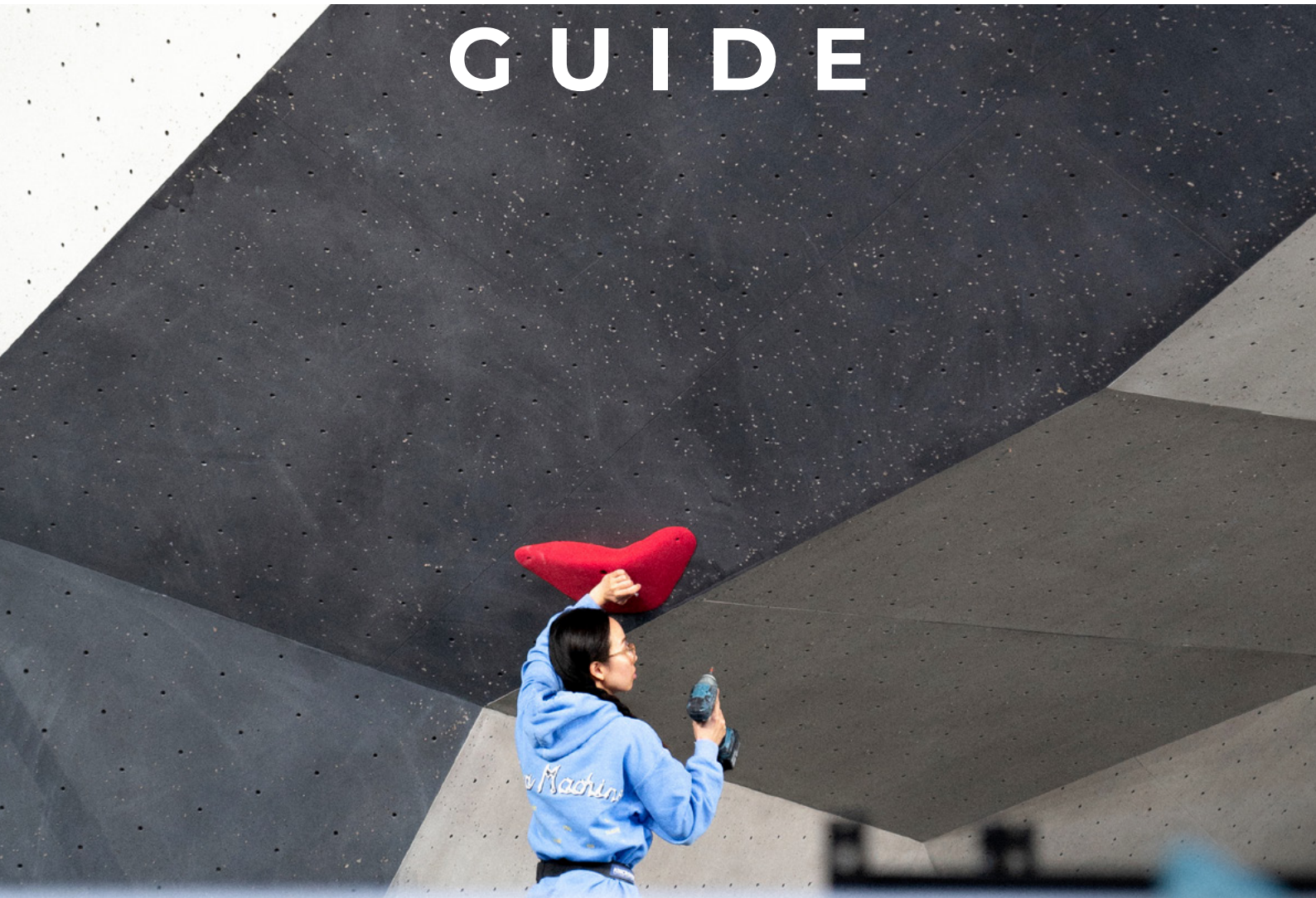

**THE AESTHETICS OF INDOOR CLIMBING**

Vertical-Life Photo Contest

**DIGITAL TOOLS IN CLIMBING GYMS**

Survey Insights

**THE CATALOG**

Featuring the Latest & Greatest Gear

# VERTICAL PRO



## VERTIKALE WELTEN

# 14. – 15. Nov. 2025

## Messe Friedrichshafen

### Sport und Arbeit in der Vertikalen – darum geht es bei der VERTICAL PRO.

Die VERTICAL PRO ist der Treffpunkt für Kletterhallen- und Seilgartenbetreiber, Seilzugangstechniker und Hilfsorganisationen. Das Thema Sicherheitstechnik ist dabei ein zentrales Thema aller Messe-Segmente. Hier bietet die Messe VERTICAL PRO ideale Synergieeffekte – nicht nur bezüglich der Produktwelt, sondern auch im Hinblick auf Testen, Kontakten, Lernen und Erfahren. Ein wichtiger Partner ist dabei der DAV mit seinem renommierten Kletterhallentreffen „Halls & Walls“. Weitere starke Partner sind der FISAT, IAPA sowie die DRK Bergwacht Württemberg.

### Vertical sport and work is what it's all about at the VERTICAL PRO.

VERTICAL PRO represents the meeting place for operators of climbing halls and high rope courses, for rope access technicians and for relief organisations. The topic of safety technology is a key theme of all segments of the fair. The VERTICAL PRO trade fair offers great opportunity for synergy – not only with regard to the product world but also when it comes to trying things out, establishing new contacts, learning new techniques and experiencing everything the industry has to offer. An important partner is the DAV with its renowned climbing hall meeting „Halls & Walls“. Other strong partners of the fair include FISAT, IAPA and German Red Cross mountain rescue Württemberg.

FOLLOW US  

[www.vertical-pro.de](http://www.vertical-pro.de)

#verticalpro

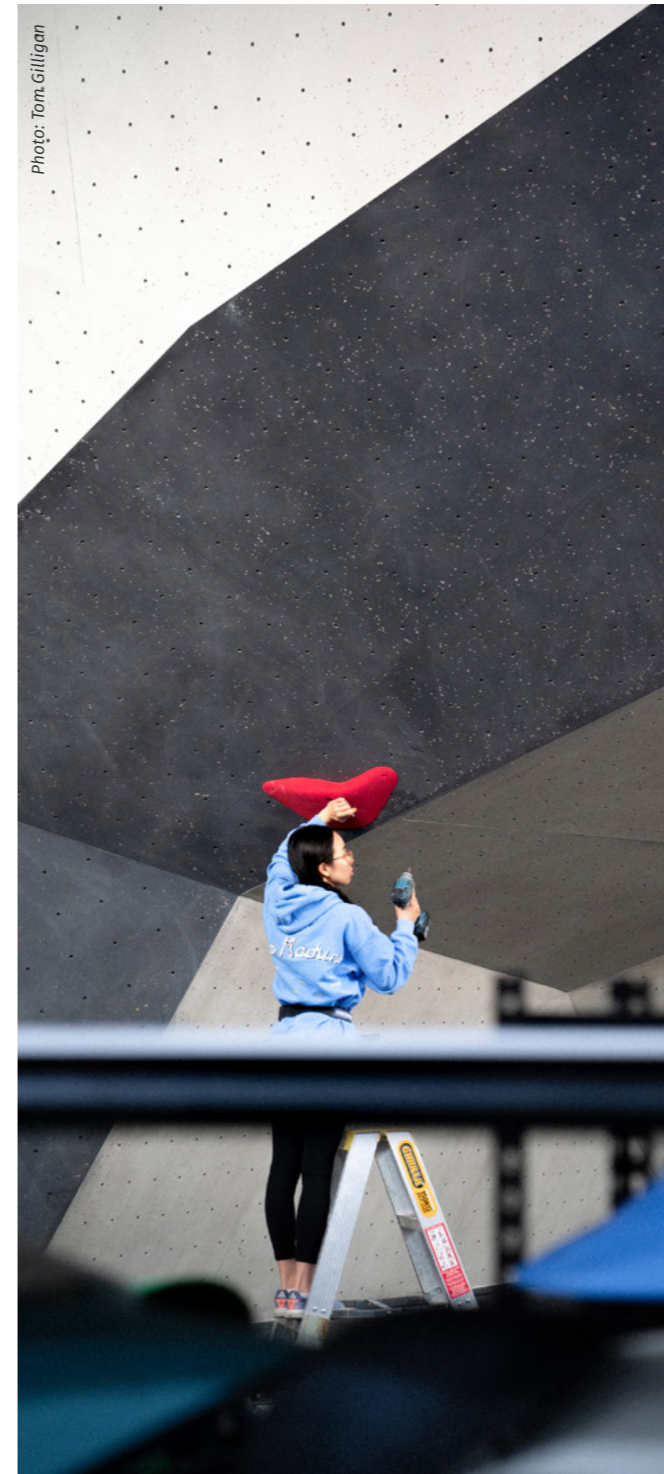

## DEAR CLIMBING COMMUNITY,

welcome to the first edition of our Gear Guide, a comprehensive catalogue for the climbing industry. We're excited to share with you the newest products from a wide range of manufacturers, all aimed at enhancing the climbing experience. This magazine reaches climbing gyms worldwide, and we're grateful that Vertical-Life is part of such a vibrant and passionate community.

The climbing gym market is evolving rapidly, becoming more professional and embracing new technologies. As gyms strive to strengthen connections with their customers, improve retention, and streamline operations, digitalization plays a crucial role. In this issue, we've included an extensive survey covering both business and consumer perspectives, highlighting the importance of adopting new solutions to meet the growing needs of climbers and gym operators alike.

As we navigate these changes together, we're committed to supporting the climbing community by sharing knowledge and resources. Whether it's through innovative gear, advanced software solutions, or collaborative efforts, our collective goal is to enhance the climbing experience for everyone.

We invite you to explore the content of this issue and hope you find inspiration in the latest trends and products shaping the future of climbing.

Warm regards,  
The Gear Guide Team  
Vertical-Life

### Editorial

*Publisher and Editors in Chief:* Matthias Polig, Maria Hilber  
*Layout:* Egon Larcher, Egle Kirdulyte  
*Contact:* [press@vertical-life.info](mailto:press@vertical-life.info)

### Catalog & Advertising

*Advertising Manager:* Simon Nagler  
*Contact:* [sales@vertical-life.info](mailto:sales@vertical-life.info)

### Cover

*Photo:* Tom Gilligan  
*Location:* 9 Degrees Lane Cove, Sydney, Australia

### Publishing House

Vertical-Life s.r.l.  
Via Brennero 32, 39042 Bressanone, Italy  
[www.vertical-life.info](http://www.vertical-life.info)

The Climbing Gym Gear Guide is published once a year in November by Vertical-Life s.r.l., available in print and in a digital edition worldwide. The magazine is devoted to climbing gyms and connected businesses.  
*Contact & orders:* [sales@vertical-life.info](mailto:sales@vertical-life.info)

All rights reserved. Copyright 2024 Vertical-Life s.r.l.



**Disclaimer:** Vertical-Life s.r.l. makes no warranties, expressed or implied, of any kind regarding the contents of this magazine, and expressly disclaims any warranty regarding the accuracy or reliability of information contained herein. Vertical-Life s.r.l. further disclaims any responsibility for injuries or death incurred by any person engaging in the activities described in the magazine.



# REGUPOL CLIMB SAFETY FLOORS – CLIMB HIGH STAY SAFE



Benefit from the advantages of our **REGUPOL climb** flooring solutions. All our products are elastic and can therefore minimise the consequences of falls. Their non-slip surfaces provide a firm grip for the person belaying. Indoors, you benefit from the seamless surface, which is both easy to clean and visually versatile. Despite the long service life of our products, signs of wear or damage can occur, which can be rectified quickly and in a resource-saving manner through repairs or re-topping. In addition to our indoor flooring, we also provide flooring solutions for outdoor areas. They offer you a number of advantages: they are water-permeable and are available in a wide range of colours. Our tile variants are easy to lay and can be replaced if necessary.

You can rely on **REGUPOL climb** – for additional safety and a pleasant ambience in your climbing hall.



Find out more about our **REGUPOL climb** products

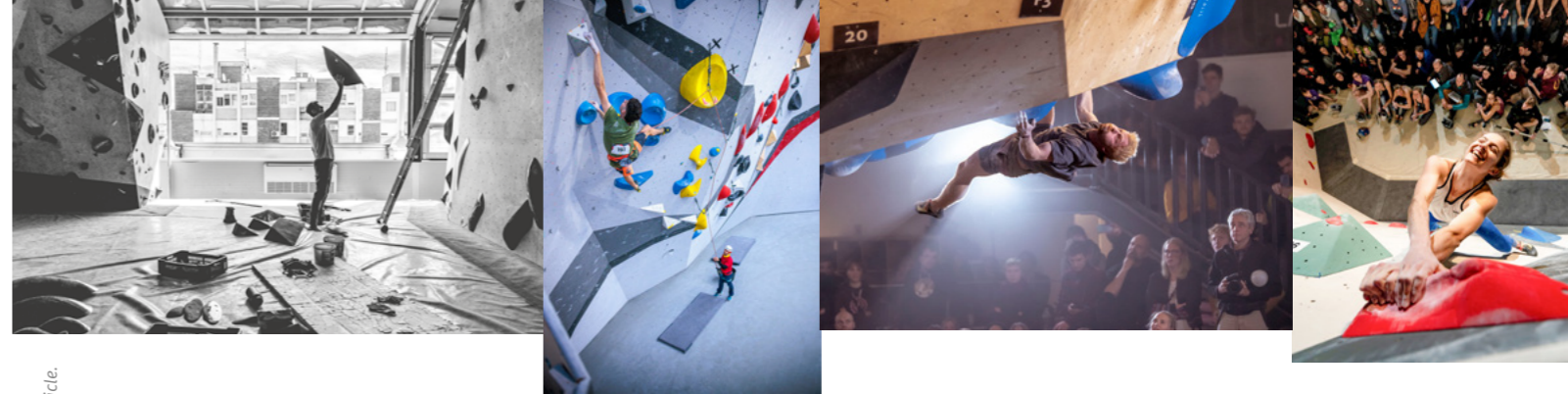

Photo: All photo details are in the Photo Contest article.

## INSIDE

#1  
2024/25

4 **VERTICAL-LIFE PHOTO CONTEST 2024** the Aesthetics of Indoor Climbing

20 **SURVEY INSIGHTS** on Digital Tools in Climbing Gyms

20 **GYM MANAGER SURVEY HIGHLIGHTS**

24 **CUSTOMER SURVEY HIGHLIGHTS**

**THE CATALOG** featuring the Latest and Greatest Gear

Software Solutions, Training Tools, Holds & Volumes, Safety & Climbing Equipment, Walls & Infrastructure

31 **VERTICAL-LIFE GYM SOFTWARE**

46 **360 HOLDS**

48 **GOOD HOLDS**

49 **NEO**

50 **SIMPL.**

51 **LYNX**

51 **READY**

52 **AGRIPP**

54 **GRIZZLY HOLDS**

56 **CHEETA**

60 **VERTEX**

62 **E-SPACE HOLDS**

64 **ARTLINE**

66 **POLYTALON**

68 **KILTER**

70 **EUROHOLDS**

72 **BAROCKA**

76 **EP-CLIMBING**

78 **CITYWALL**

80 **BENKY CLIMBING**

84 **WALLTOPIA**

90 **BÄNFER**

92 **BLOCZ**

94 **BLUEPILL**

95 **COMMUNITY CLIMBING EQUIPMENT**

96 **KLETTERKULTUR**

97 **RE:WHITE**

98 **BEAL**

100 **9C PROFESSIONAL**

102 **JEZ TAPPING**

104 **ATARI CLIMBING**

106 **BOULDERBALL**

108 **ONE4ALL**

110 **MUSKERS**



**Vertical-Life**  
PHOTO  
CONTEST  
2024

[www.vertical-life.info](http://www.vertical-life.info)

## VERTICAL-LIFE PHOTO CONTEST 2024

### THE AESTHETICS OF INDOOR CLIMBING

*This year's Vertical-Life Indoor Climbing Photo Contest brought The Aesthetics of Indoor Climbing to life. We invited climbers to capture the striking visuals that make indoor climbing unique—vibrant movements, artistic routesetting, inspiring walls, and, most importantly, the people who bring these spaces to life. Each image shows how climbing gyms are more than walls; they're dynamic hubs of creativity, community, and challenge.*

Through these photos, the full story of indoor climbing unfolded—from intense training sessions and relaxed social climbs to the intricate art of routesetting and the thrill of competition.

We're excited to showcase this selection of standout entries, including this year's winners and crowd favorite. A huge thank you to everyone who shared their vision and to our sponsor, Beal, for supporting this year's contest. We hope you enjoy this visual journey through the vibrant world of indoor climbing!

**Beal**

HIGHLY  
FRIENDLY

Photo: Milan Herens

**1ST PLACE**

PRIZE-GIVING CEREMONY  
by Grzegorz Marcineki

📍 Arena Wspinaczkowa Makak, Warsaw, Poland



## 2ND PLACE

by Paul Lewandowski

📍 Innsbruck, Austria



## 3RD PLACE

*GRACE STARTING OFF STRONG*  
by Tom Gilligan

📍 9 Degrees Lane Cove, Sydney, Australia

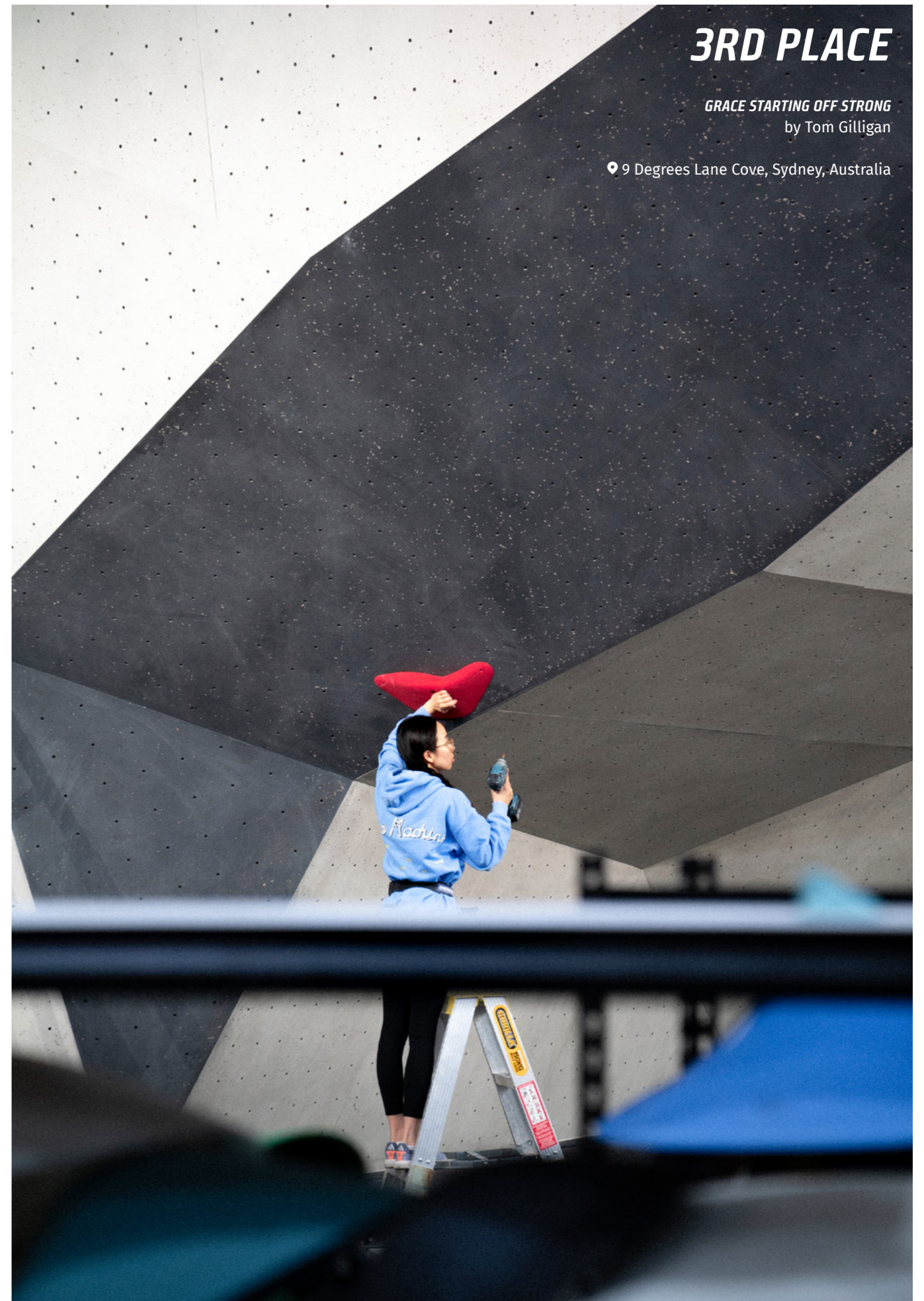

**CROWD FAVORITE**

**OSTBLOCKCUP FINALS AT BOULDERLOUNGE CHEMNITZ**  
by Fabian Fischer

📍 Boulderlounge, Chemnitz, Germany



**IN THE NAME OF CREATIVITY**  
by Matej Kožič

📍 The Hive, Zagreb, Croatia



**LITTLE LOCAL COMP AND SOME SLAB ACTION**  
by Filippo D'Ambrosio

📍 Manga Climbing, Milano, Italy



**LAST MINUTE PREPARATIONS AS CHIEF ROUTESETTER DURING THE DUTCH LEAD NATIONALS 2022**  
by Sietse van Slooten

📍 IVY Climbing, Sittard, Netherlands





**COMPETITION**  
by Javi Pec

📍 Indoorwall, Alicante, Spain



**FINAL**  
by Grzegorz Marcinek

📍 Arena Wspinaczkowa Makak, Warsaw, Poland



by Silver Breiktopf

📍 Klättercentret Telefonplan, Hägersten, Sweden

**PEEK AT THE SETTERS TESTING THE BLOCS**  
by Tom Gilligan

📍 9 Degrees, Alexandria, Australia

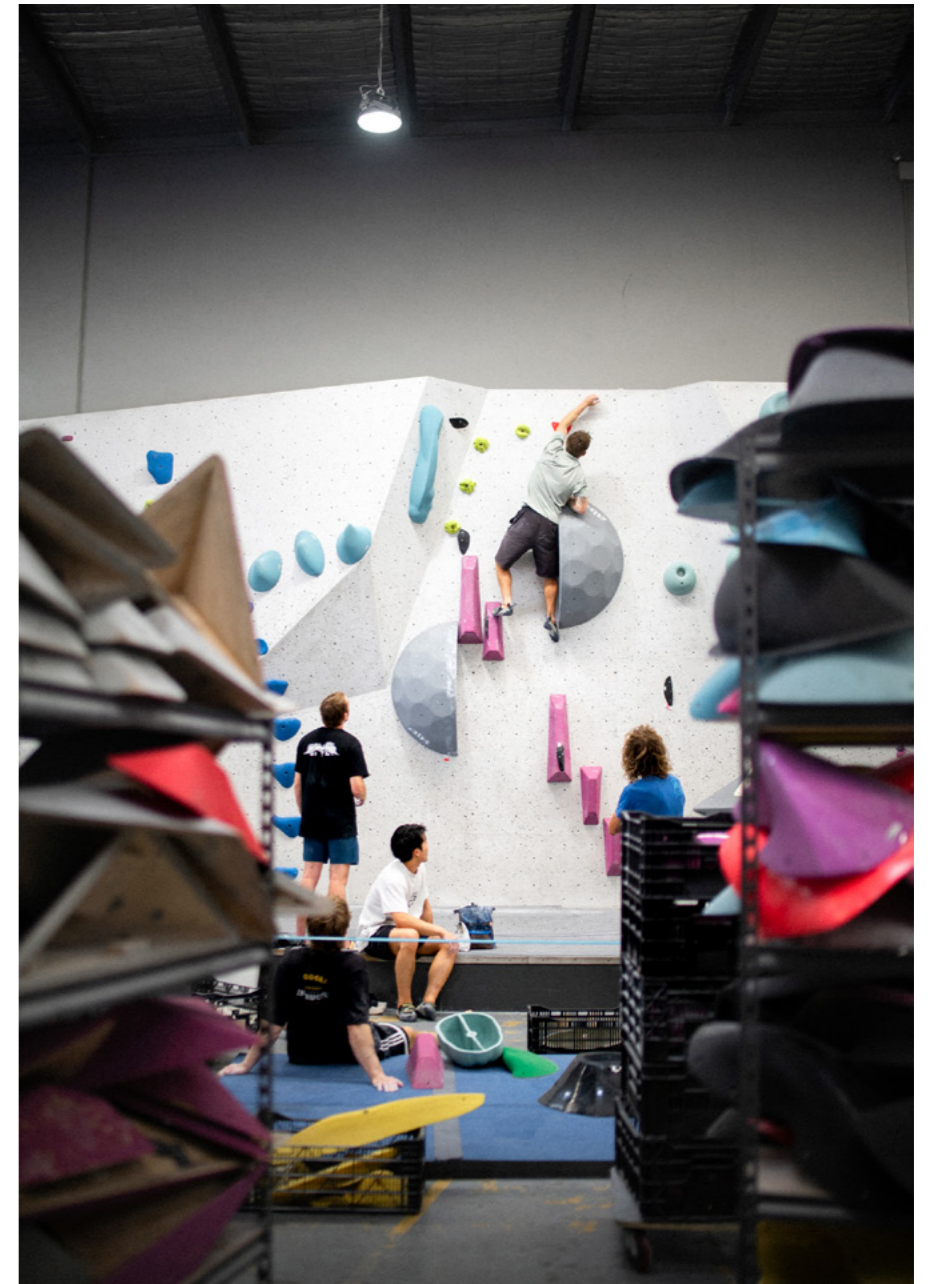

**FLASH ART**  
by Milan Herens

📍 Graviton Bouldergym, Sittard, Netherlands



**FINALS OF PORTSIDE BOULDERS' 2024**  
**WEST COAST BLOCS COMPETITION.**  
by Andrew Anderst

📍 Portside Boulders (Osborne Park), Perth, Australia



**LONG MOVE**  
by Javi Pec

📍 Indoorwall Climbing Centers, Alicante, Spain



by Gabriel Buca

📍 The Project Climbing Centre, Poole, United Kingdom

**QUIET DAY IN THE GYM**  
by Rachel Gill

📍 Awesome Walls, Cork, Ireland



**3-POINT-RULE WHEN CLIMBING**  
by Lara Novak

📍 KI, Innsbruck, Austria

**ROUTEREADING**  
by Silver Breiktopf

📍 Klättercentret Telefonplan, Hägersten, Sweden



**SUNSET AT RADIUM**  
by Milan Herens

📍 Radium Boulders, Maastricht, Netherlands



**PRACTICE SESSION WITH SOLNA CLIMBING TEAM**  
by Anders Nystedt

📍 Klättercentret Akalla, Kista, Sweden





by Daniela Andrei

📍 Klimcentrum Bjoeks, Groningen, Netherlands



by Chuckie Pe

📍 The Bouldering Hive, Makati, Philippines



**SETTING**  
by Milan Herens

📍 Radium Boulders, Maastricht, Netherlands



**LUCIA ON THE RED CARPET AT OSTBLOC**

by Fabian Fischer

📍 Ostbloc, Berlin, Germany



by Gabriel Buca

📍 The Project Climbing Centre, Poole, United Kingdom



**OSTBLOCKCUP AT 45 GRAD**  
by Fabian Fischer

📍 45 Grad, Rostock, Germany



by Sylvain

📍 Climb Up, Aubagne, France



**ELAINE AT FLASHMASTERS FINALS**  
by Phil Hector

📍 The Project Climbing Centre, Poole, United Kingdom



**A REACH FOR THE SPOTLIGHT**  
by Aaron Koons

📍 Sportrock Rio, Gaithersburg, Maryland, USA



**ROUTESETTING: THINKING ABOUT THE NEXT HOLD.**  
by Milan Herens

📍 Radium Boulders, Maastricht, Netherlands

BY LABWORK



# Die steile Kunst des Kletterns.

Steilheit GmbH  
Wildbichler Straße 1d  
6341 Ebbs  
Tirol in Österreich

servus@steilheit.com  
+43 5373 21 233 - 0

www.steilheit.com

Wir revolutionieren den Klettersport durch wegweisende Designs, hochwertige Materialien und modernste Technologien. Unsere Kletterwände vereinen technische Herausforderungen mit beeindruckender Ästhetik und sind von der Natur inspiriert. In enger Kooperation mit professionellen Kletterern haben wir Strukturen geschaffen, die Kreativität und Anspruch harmonisch zusammenbringen. Gemeinsam formen wir die Zukunft des Kletterns – dynamisch, individuell und voller unentdeckter Potenziale.

# LUCHA

# LIBRE

Unveiling Flathold's latest Lucha Libre Collection designed by Manuel Hassler. These dual-textured slopy-jugs and flat-crimps offer a unique challenge to all climbers. Experience the thrill of climbing with Lucha Libre's nuanced and distinctive style.



# SURVEY INSIGHTS ON DIGITAL TOOLS IN CLIMBING GYMS

SURVEY CONCEPT & ANALYSIS BY VERTICAL-LIFE



*In recent months, we've reached out to understand the needs and experiences within the climbing community. We conducted two surveys: one with 140 gym owners and managers, and another with 1,500 climbers who frequent these gyms.*

The first survey focused on gym professionals' perspectives on digital tools, the everyday challenges of running a gym, and how a comprehensive software solution like Vertical-Life could assist in their operations. The second survey aimed to gather

climbers' insights on their routines, experiences, and what they expect from digital services provided by gyms.

In this article, we'll share the findings from these surveys. Our goal is to offer straightforward insights that can help routesetters and gym managers make practical decisions about incorporating digital tools into their gyms. We hope this information proves useful as you navigate the evolving landscape of gym management and customer engagement.

## GYM MANAGER SURVEY HIGHLIGHTS

**1. Which of the following does your climbing gym offer?** See B2C Q 3 for comparison.

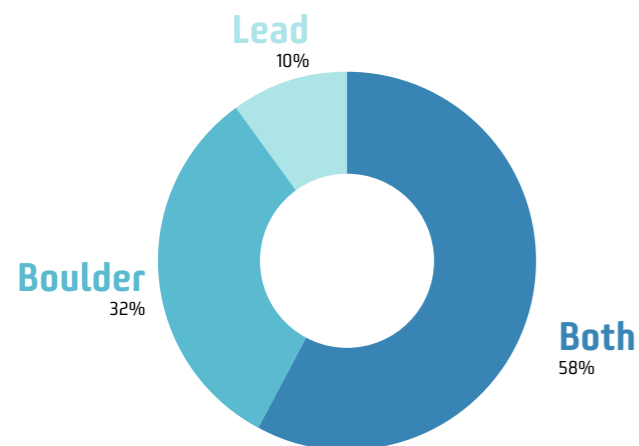

**2. What is currently the biggest challenge in running your climbing gym?**

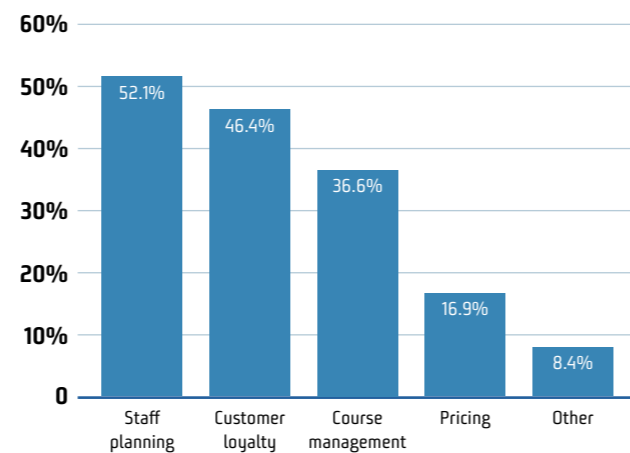

**3. How much time per week do you or your team spend on administrative tasks?**

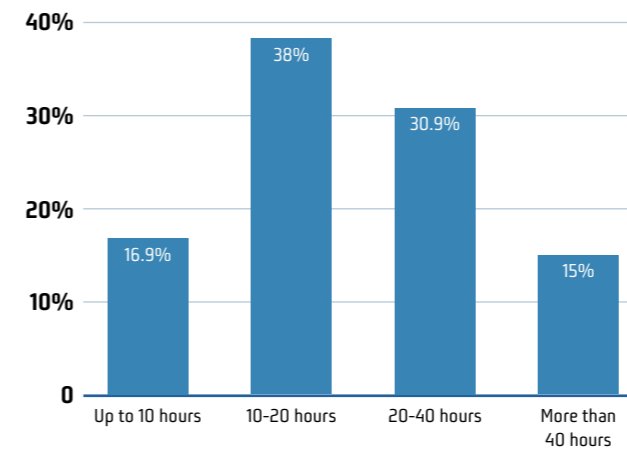

**4. How would you rate the efficiency of your current software solutions on a scale of 1-10? -> Average 6.5**

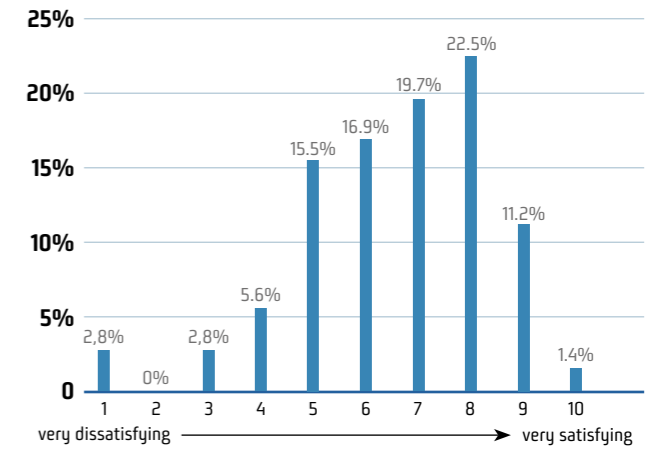

**5. Which software solutions do you currently use in your climbing gym?**

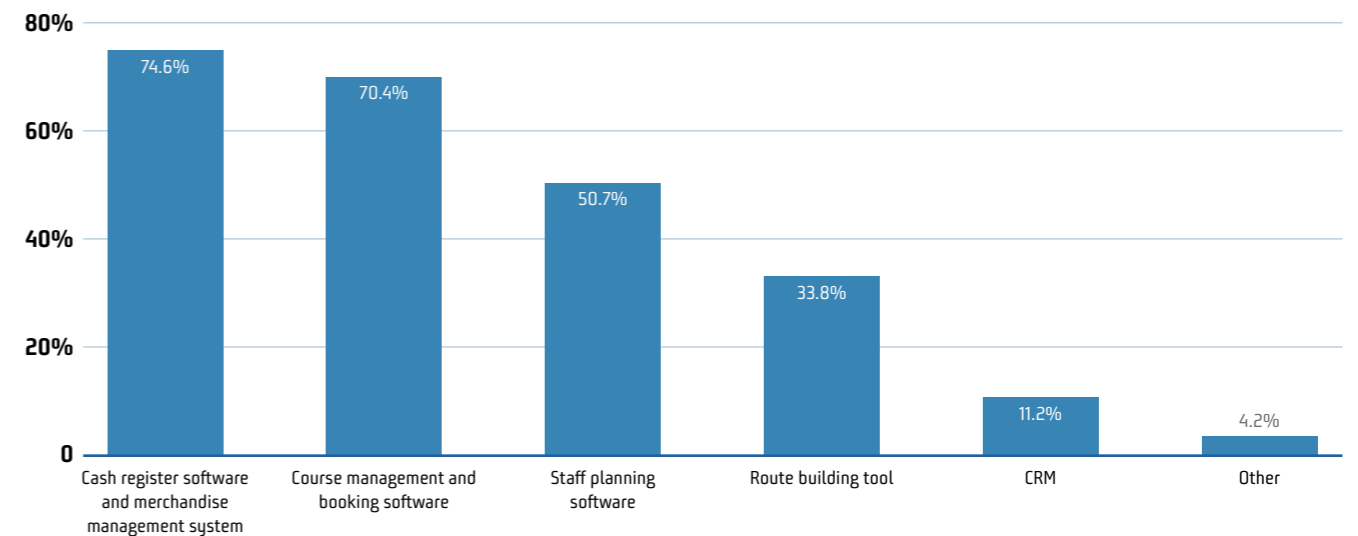

**6. What functions are missing in your current software solution?**

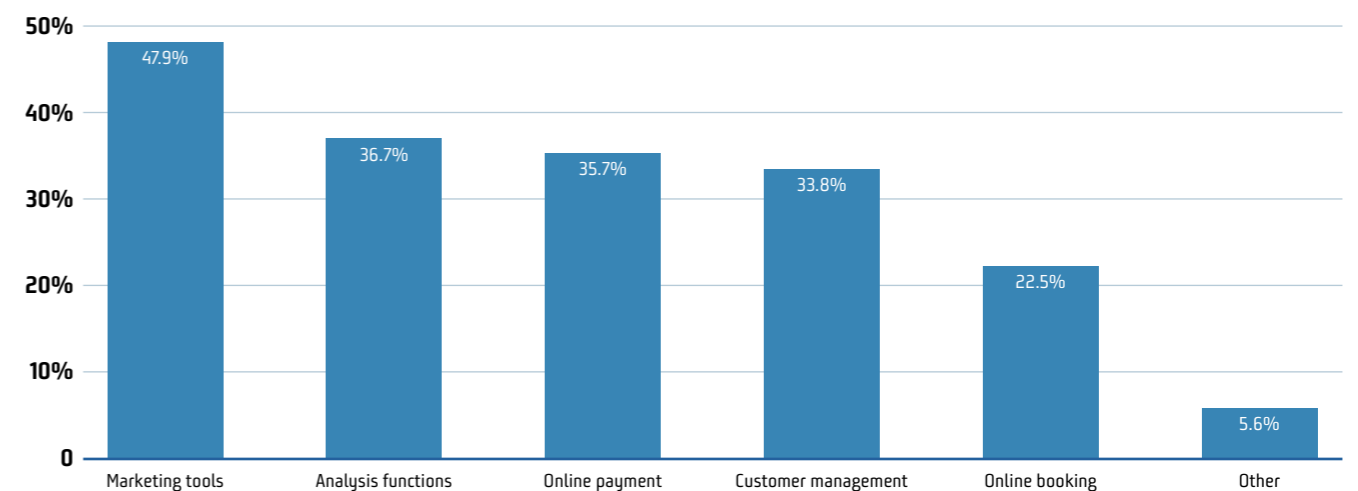

**7. Which communication channels do you mainly use to engage with customers?**

See B2C Q 29 for comparison.

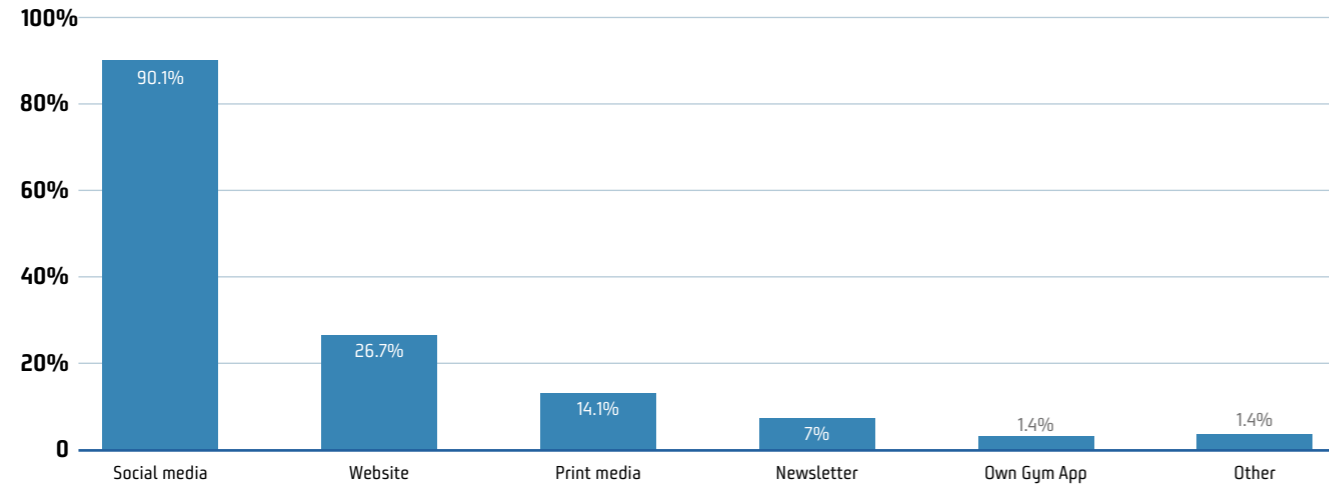

**8. How important is the automation of recurring tasks to you?**

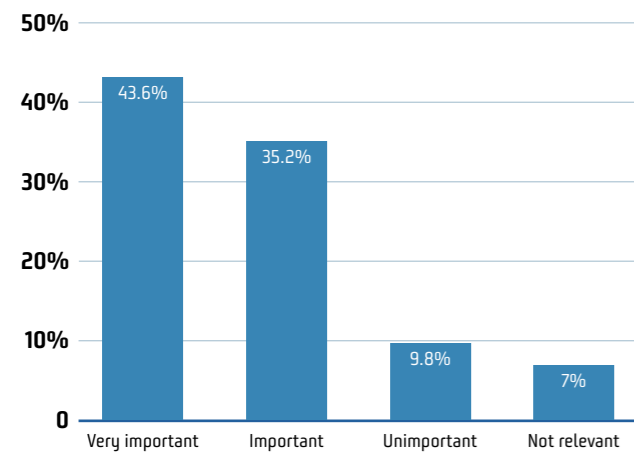

**9. How open are you to using new technologies such as AI or automated analytics tools in your climbing gyms?**

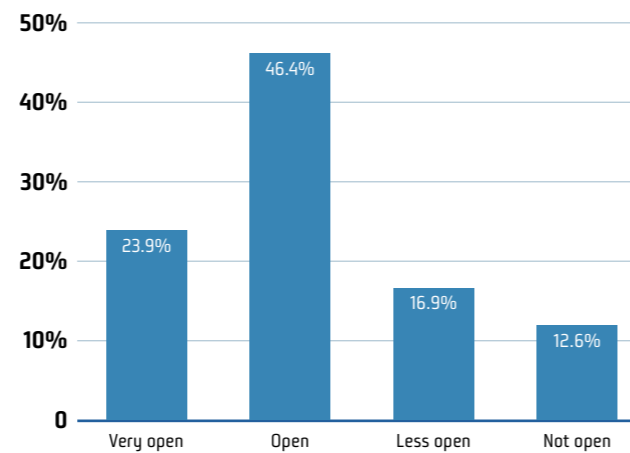

**10. Would you be interested in an individual app for your gym with ticketing, courses, route setting and chat functions?**

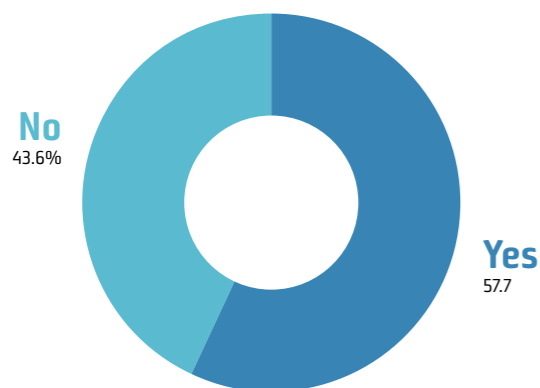

**11. Do you plan to expand or renovate your climbing gyms in the next 1-2 years?**

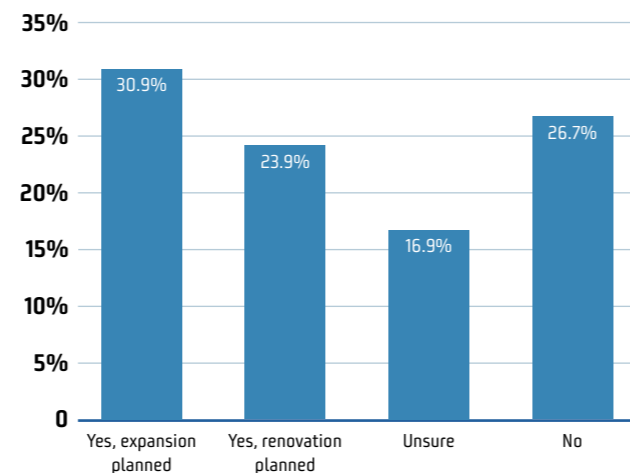

**12. Do you sell entry tickets online?**

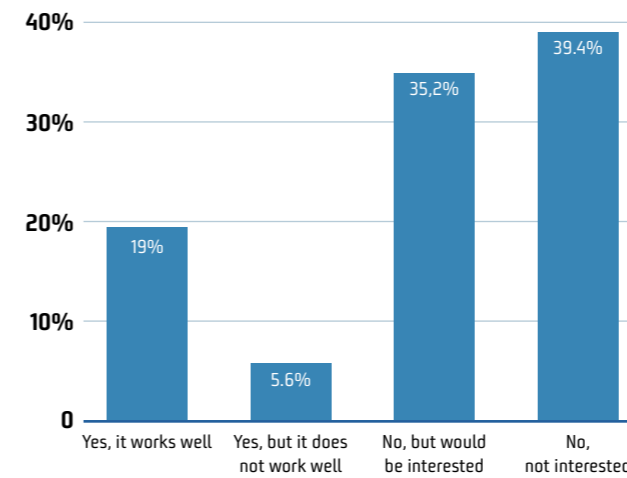

**13. How would you assess the potential of external membership providers for your climbing gym?**

See B2C Q 23 for comparison.

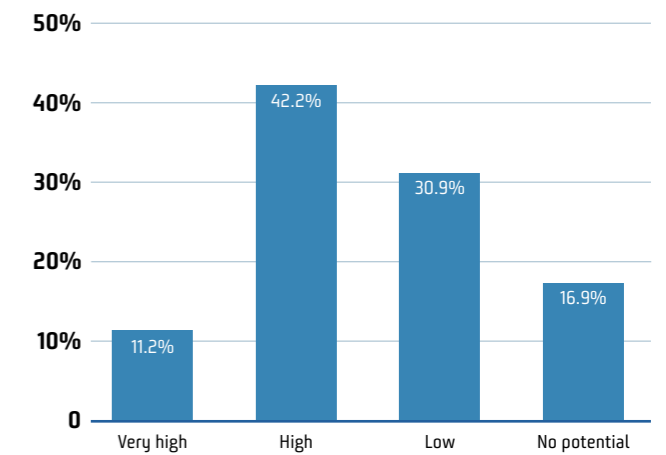

**14. What challenges do you see in integrating external membership providers?**

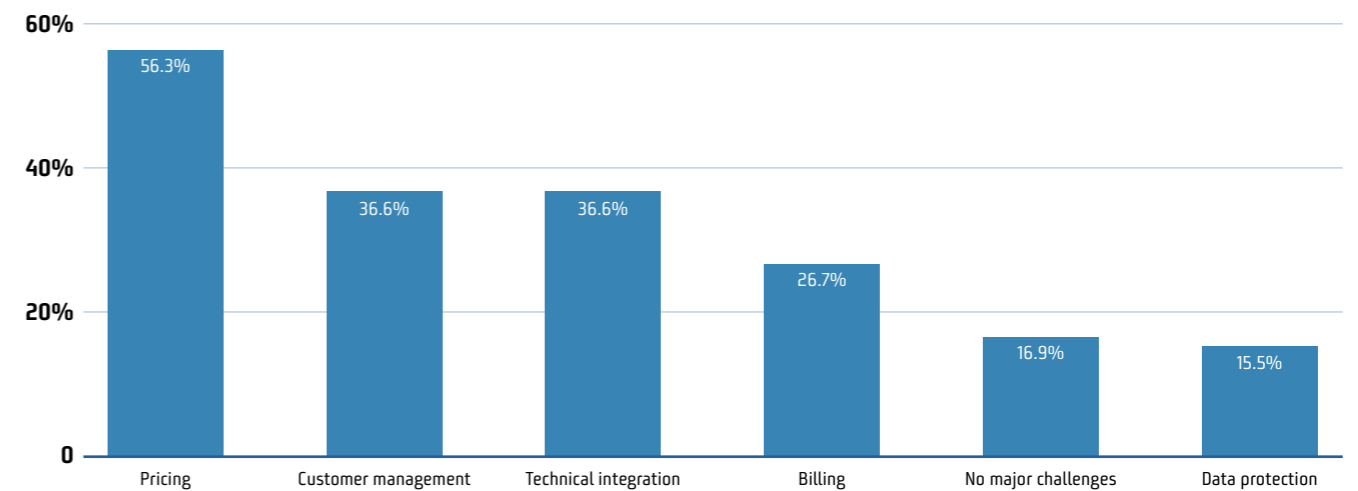

**15. Would you consider offering a Climbing Gym Network Card in partnership with other gyms, or do you already offer one? See B2C Q 25 for comparison.**

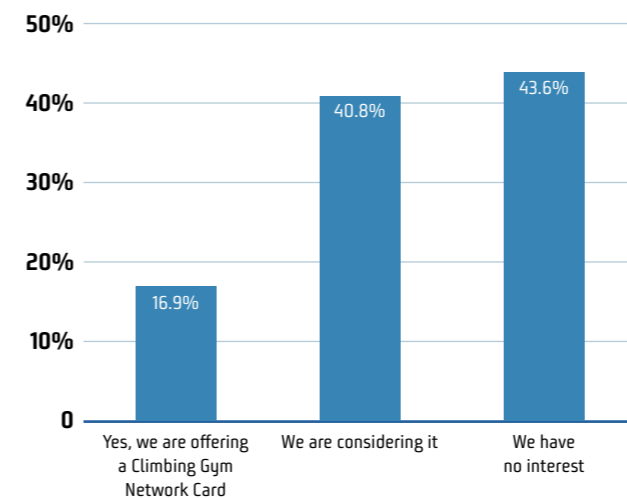

**16. What advantages do you expect from a Climbing Gym Network Card?**

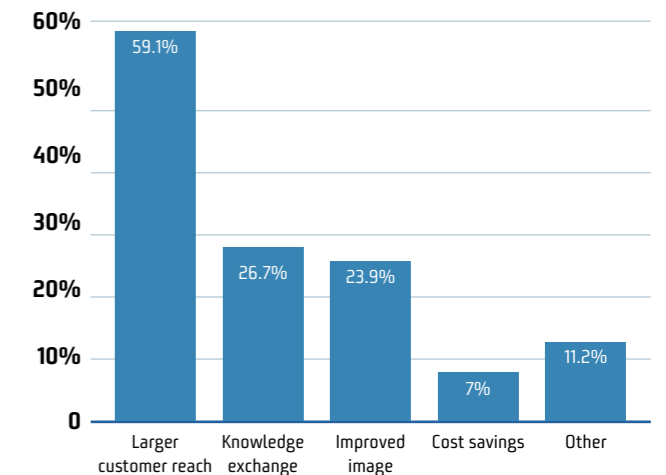



3. How long have you been climbing or bouldering?

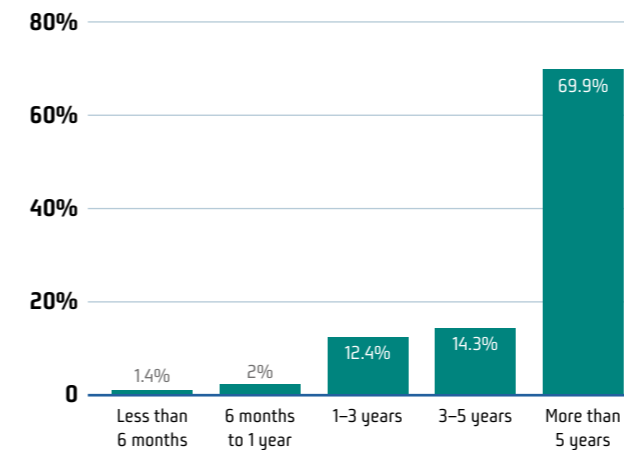

4. How often do you visit a climbing gym?

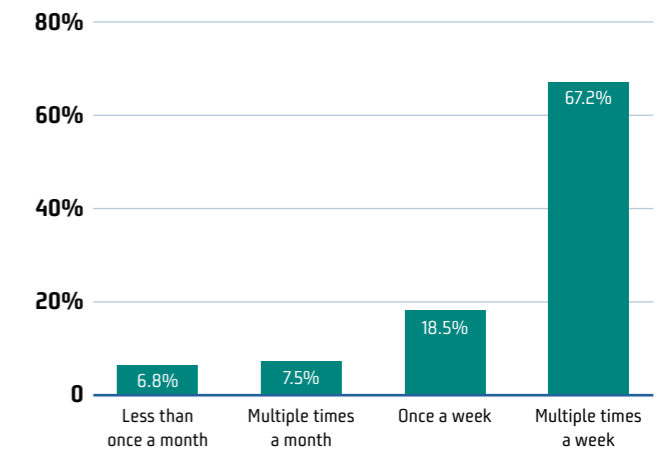

5. Which climbing discipline do you primarily practice?  
See B2B Q 1 for comparison.

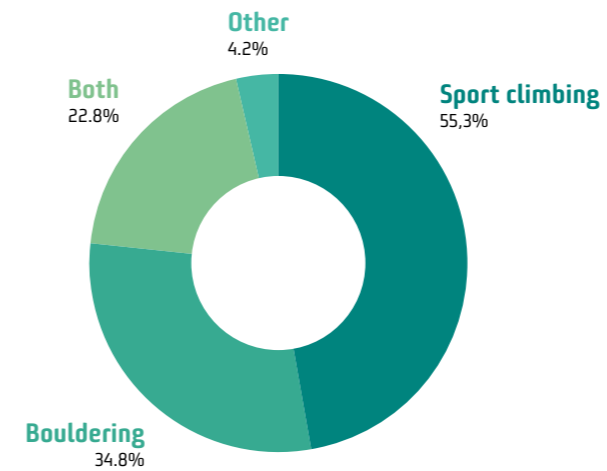

6. How would you rate your climbing level?

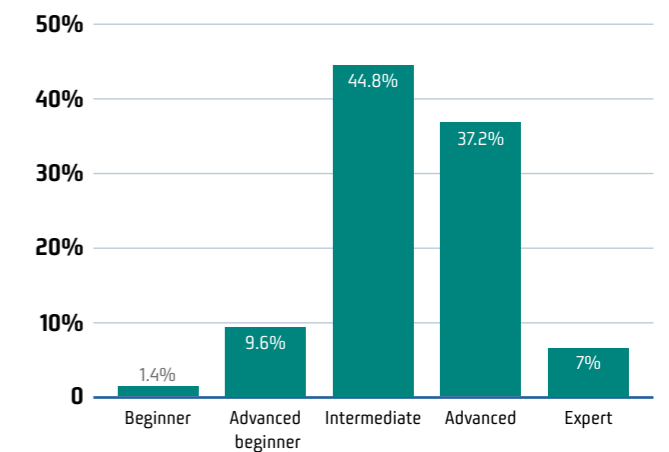

## CUSTOMER SURVEY HIGHLIGHTS

1. Gender

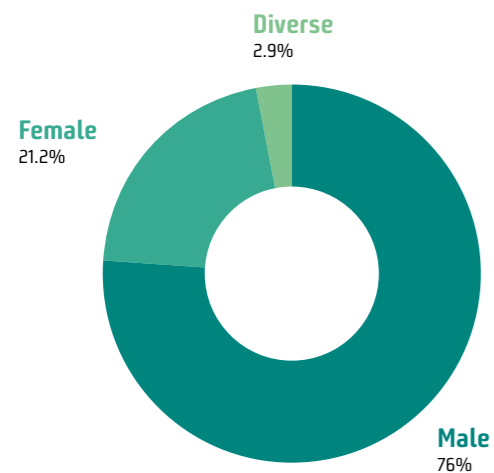

2. Which age group do you belong to?

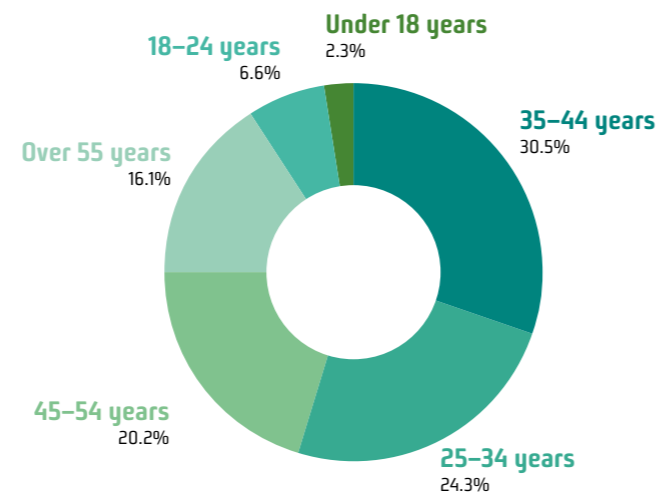

7. What mainly motivates you to climb?

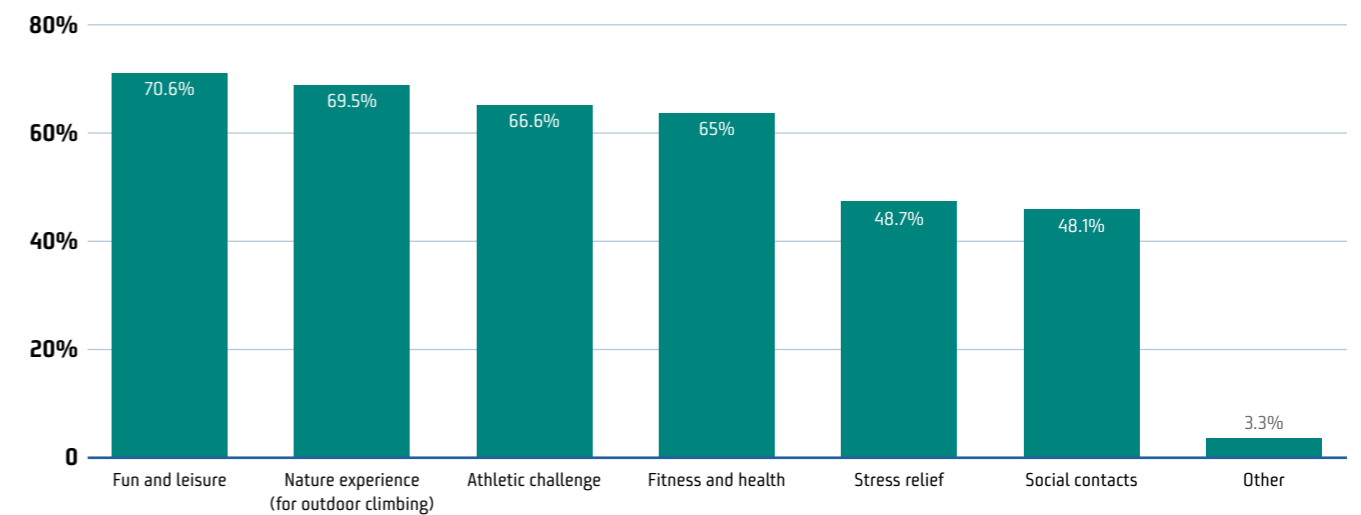

**8. Do you also climb outdoors on rock?**

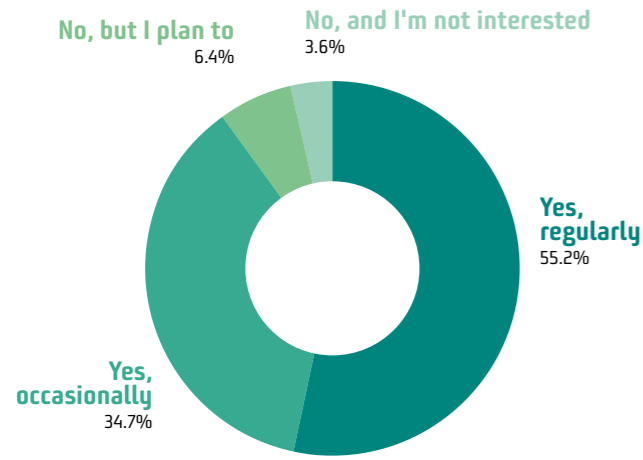

**9. Do you currently use an app or software to support your climbing activities?**

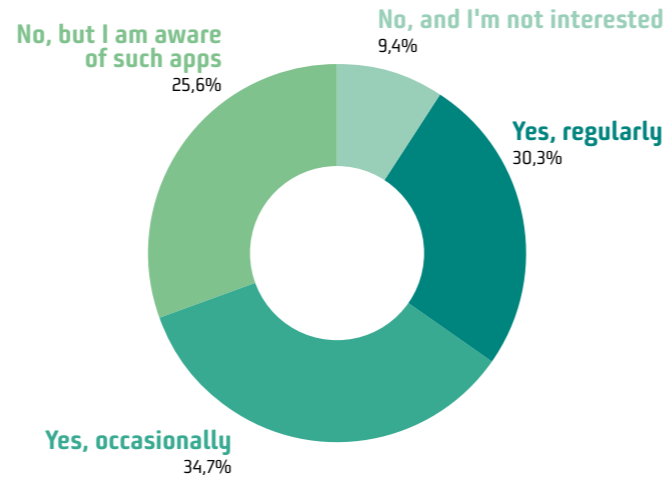

**10. Which features of a climbing app or software are particularly important to you?**

See B2B Q 5/6 for comparison.

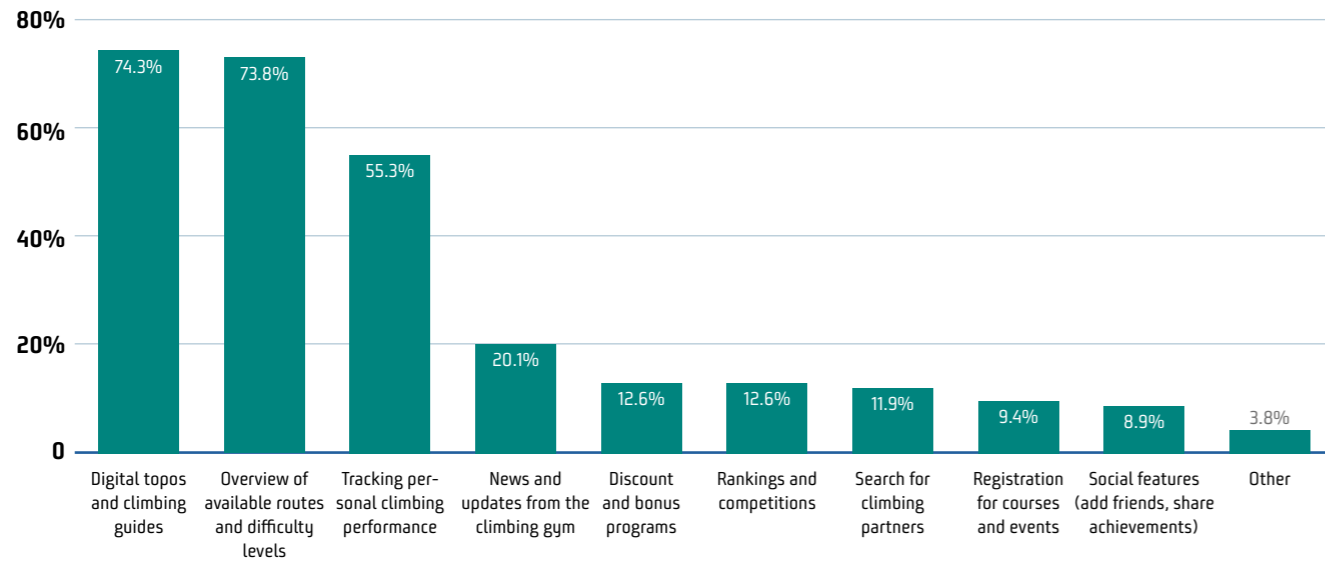

**11. How important is the ability to find climbing partners via an app to you?**

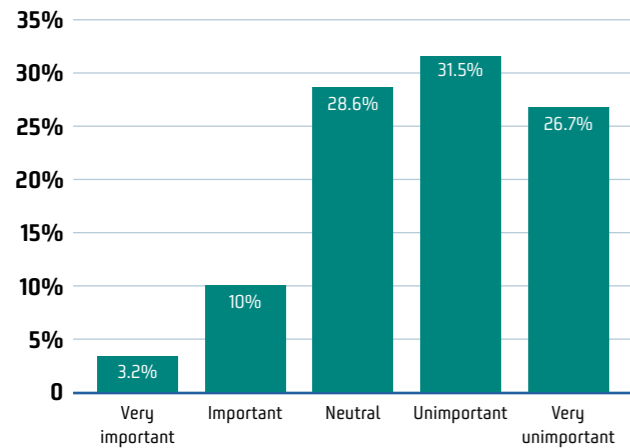

**12. How important is it for you to interact with other climbers via a digital platform or app?**

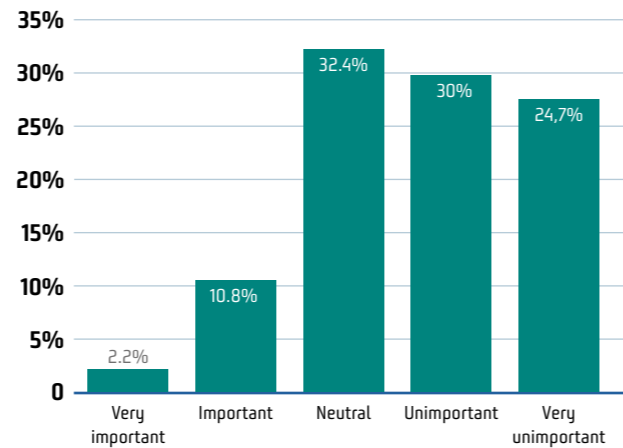

**13. How do you usually sign up for courses or events at your climbing gym?**

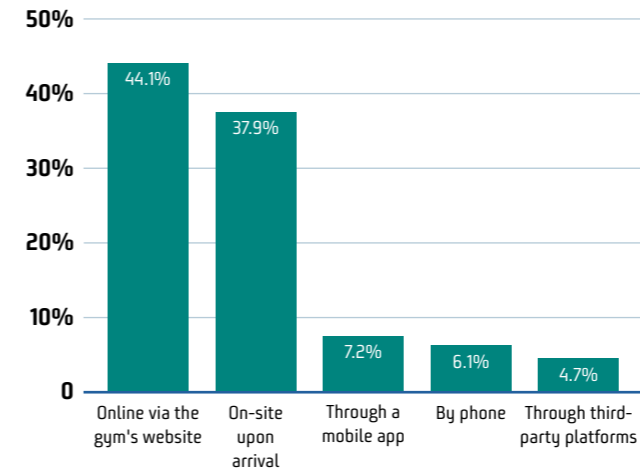

**14. How important is the ability to sign up online for courses or events to you?**

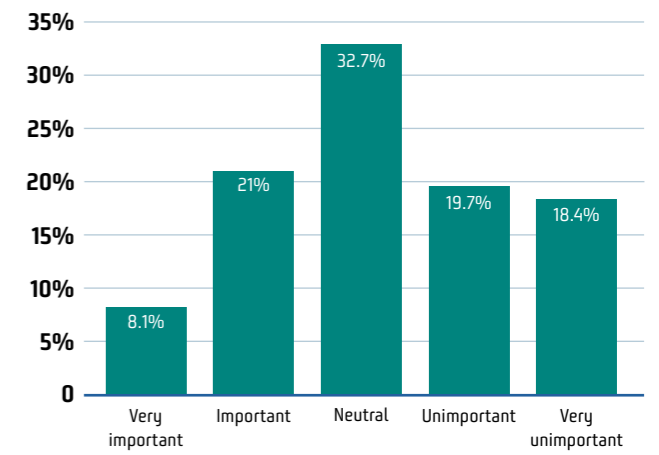

**15. How satisfied are you with the current digital offerings of your climbing gym?**

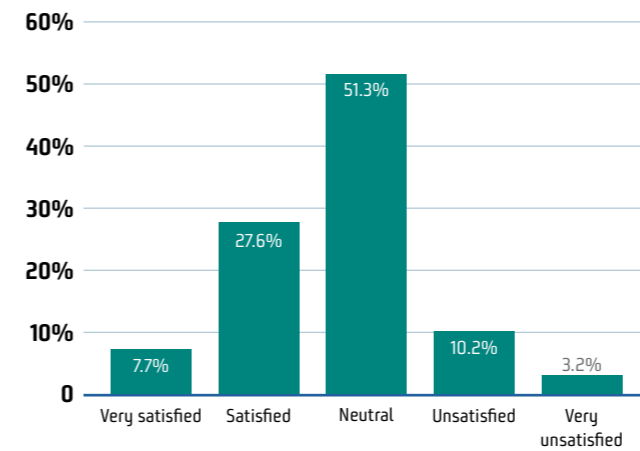

**16. How important is the ability to track your climbing progress digitally and be supported by your climbing gym with training plans, exercises, or digital training tips?**

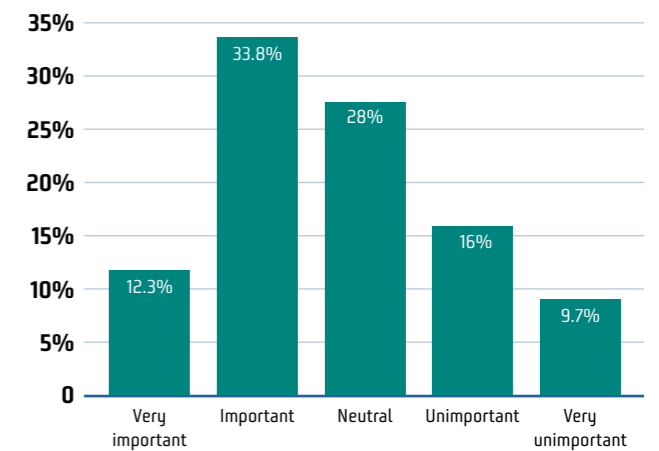

**17. What improvements would you like to see in the digital offerings of your climbing gym?**

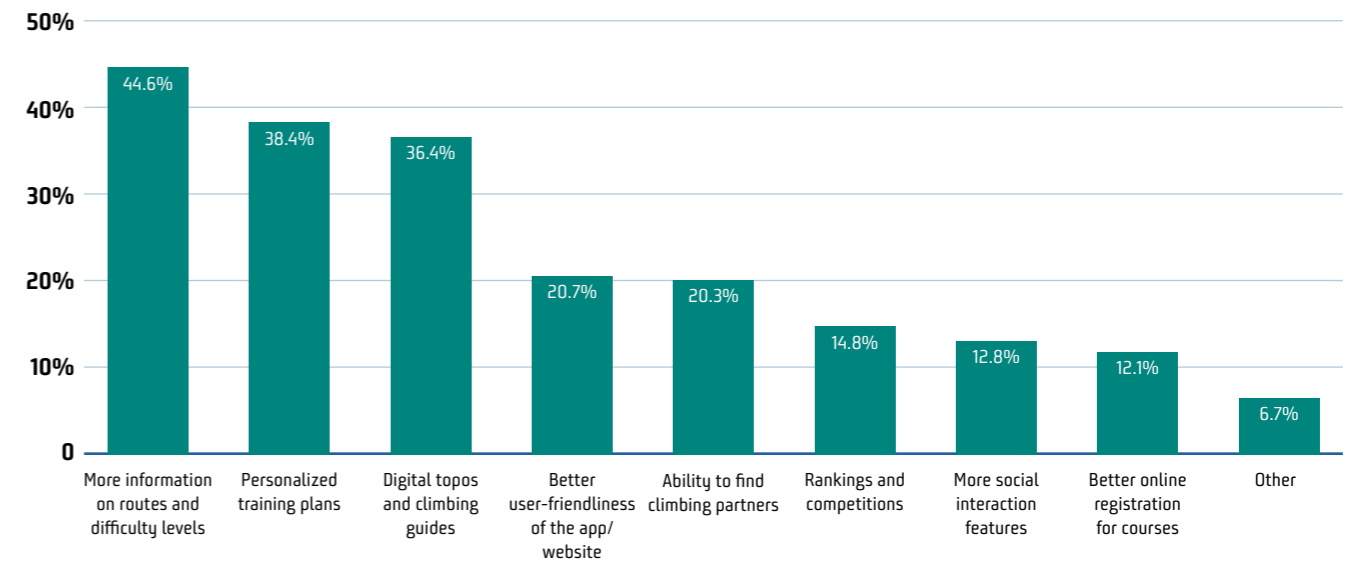

18. Would you be interested in a digital training subscription or online courses offered by your climbing gym?

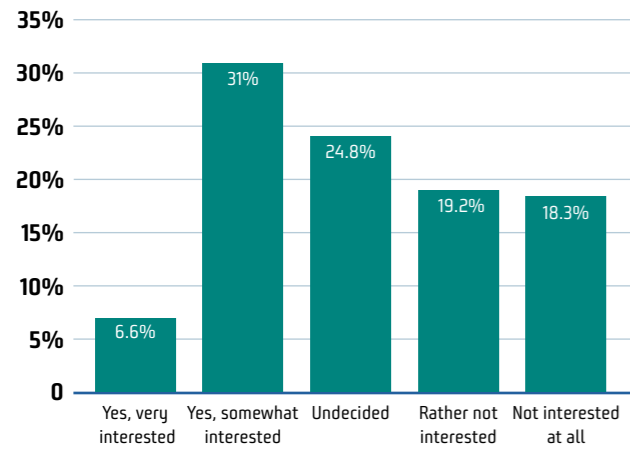

19. Would you pay for personalized training plans or training tips created by professional trainers at your climbing gym?

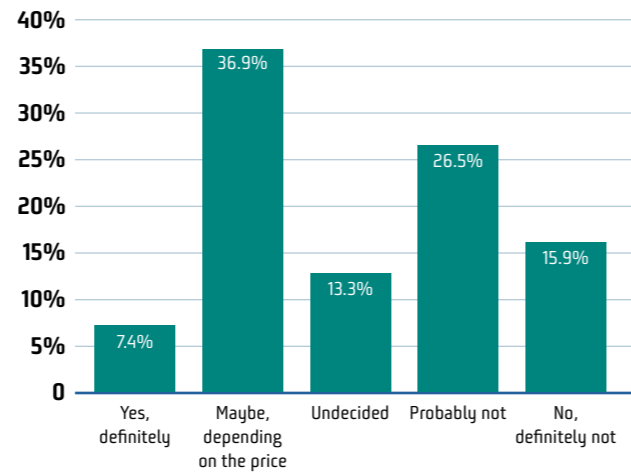

20. Would you participate in digital challenges or competitions offered by your climbing gym or an app?

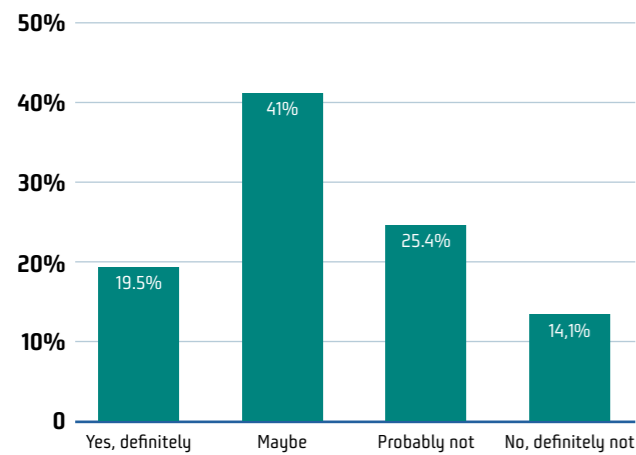

21. How important is the integration of fitness or multi-ticket providers for accessing the climbing gym to you?

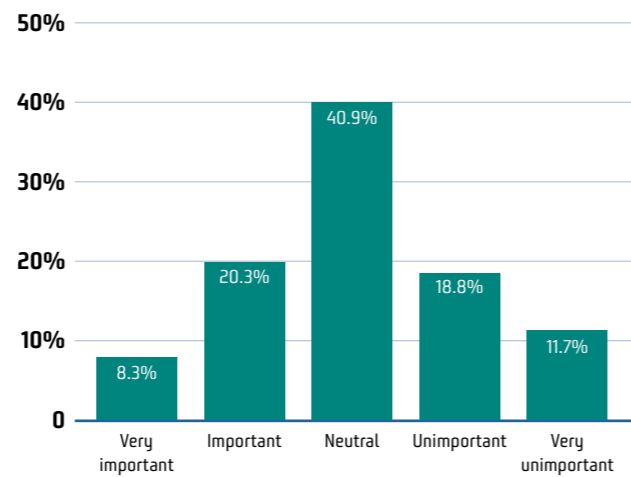

22. Which payment methods do you prefer for entries and courses at the climbing gym?

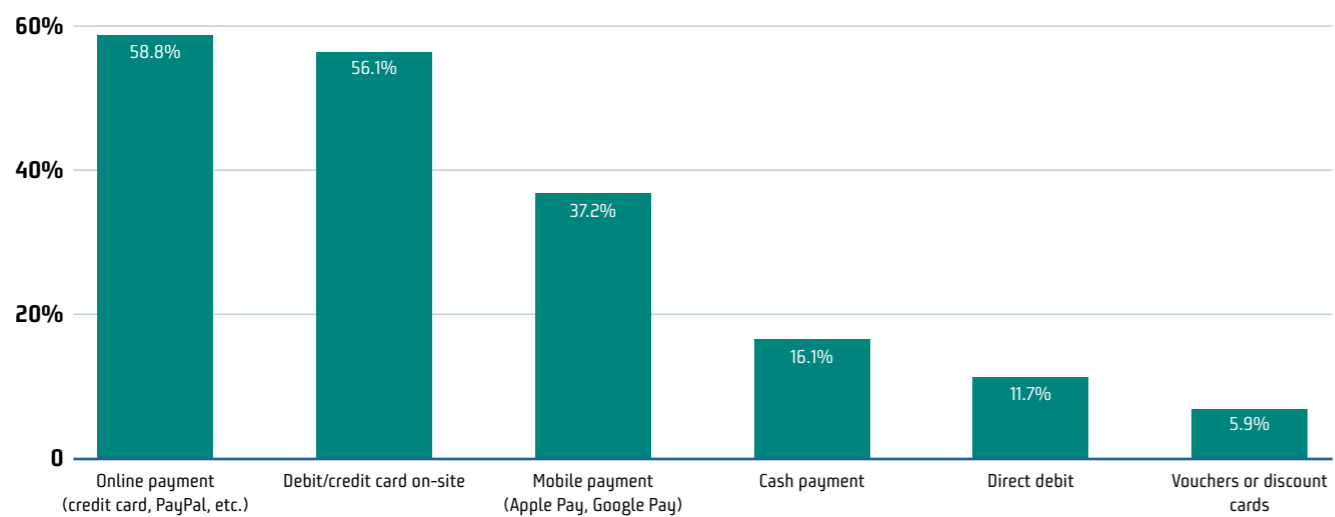

23. Do you currently use multi-ticket providers for accessing climbing gyms? See B2B Q 13 for comparison.

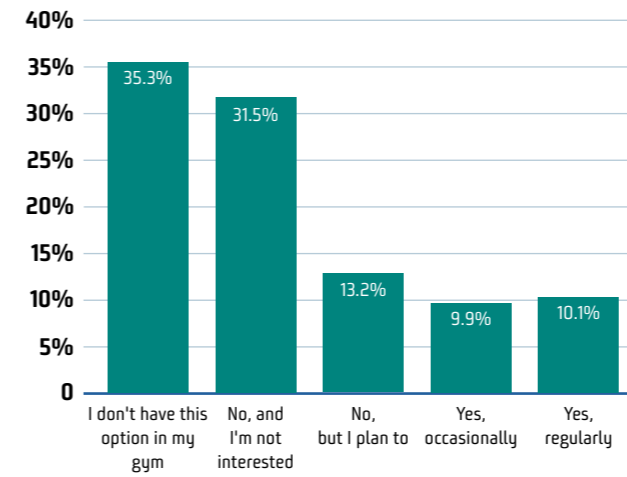

24. Do you mainly use multi-ticket providers for accessing climbing gyms or for combining with other sports?

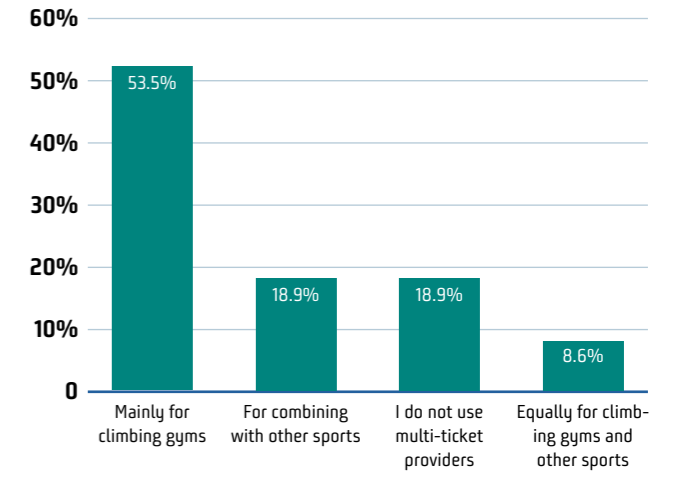

25. How likely are you to use (or would you use) a membership that gives you access to multiple climbing gyms? See B2B Q 15 for comparison.

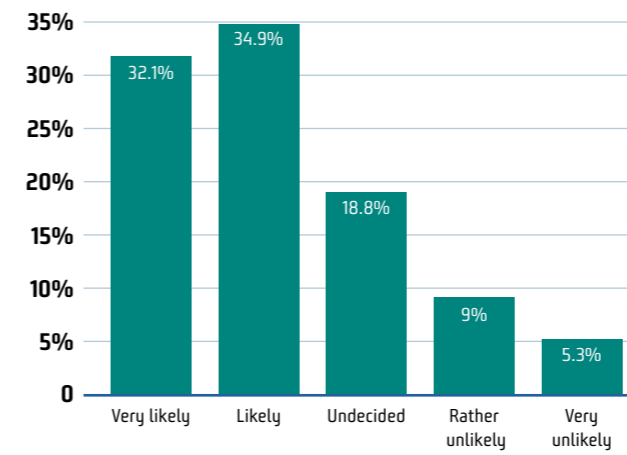

26. How likely are you to recommend your climbing gym to friends or colleagues? -> Average 8.4

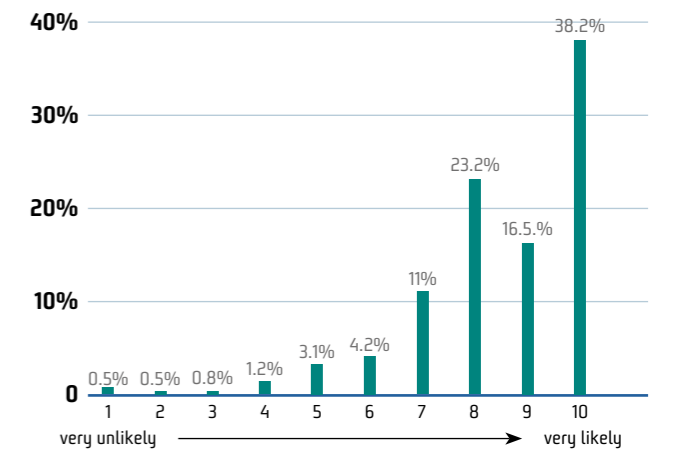

**28. How do you inform yourself about new routes, courses, or events in your climbing gym?**

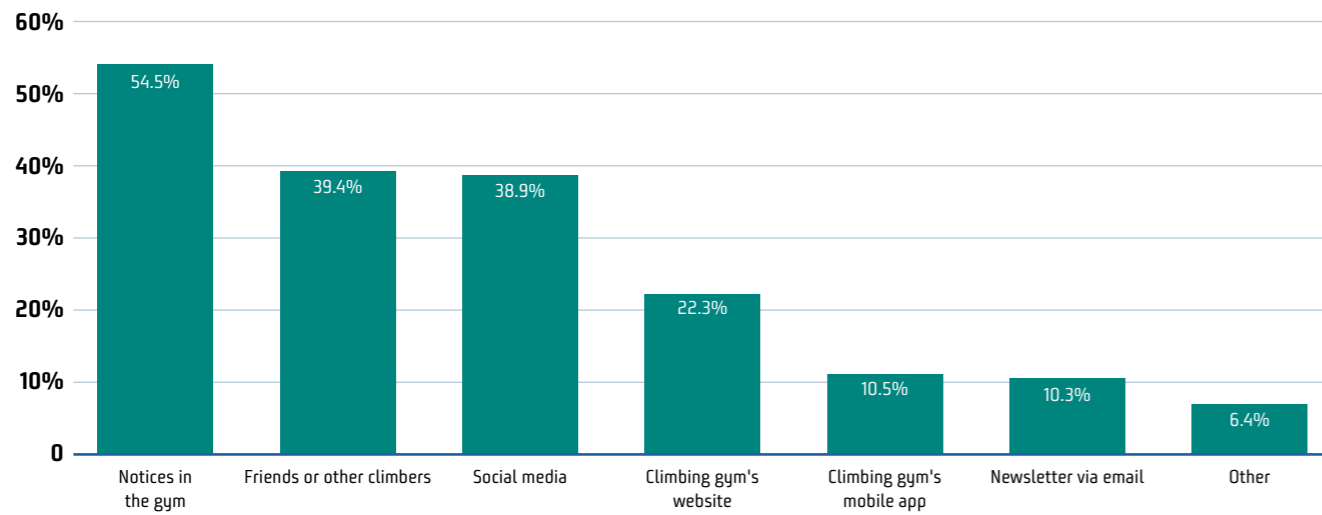

**29. Which communication channels do you prefer for information and offers from your climbing gym?**

See B2B Q 7 for comparison.

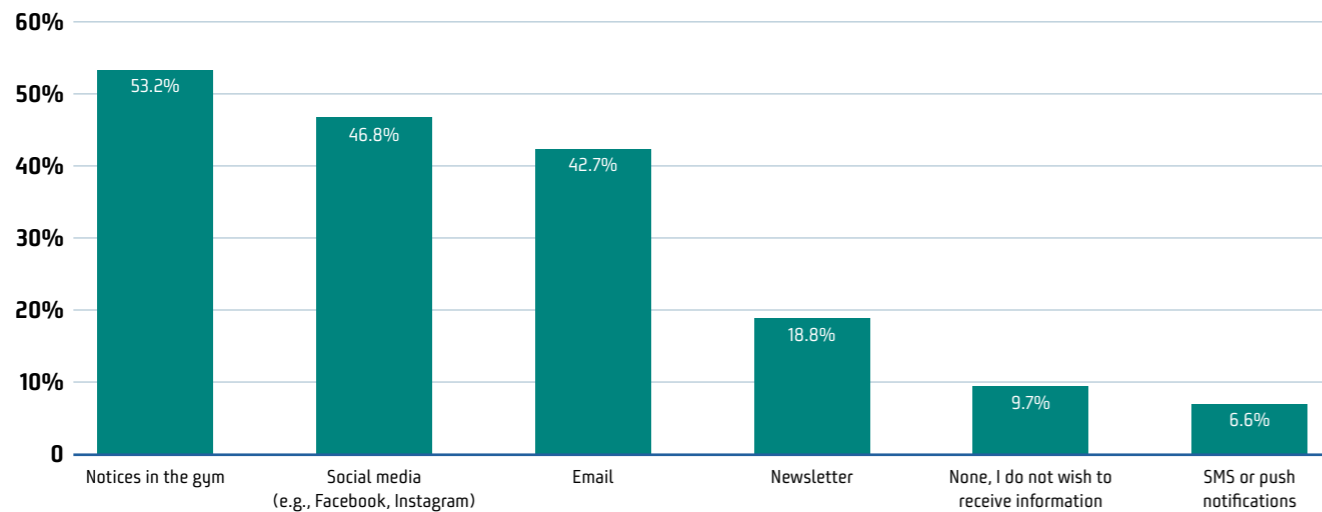

**30. Which of the following digital features would most enhance your climbing experience?**

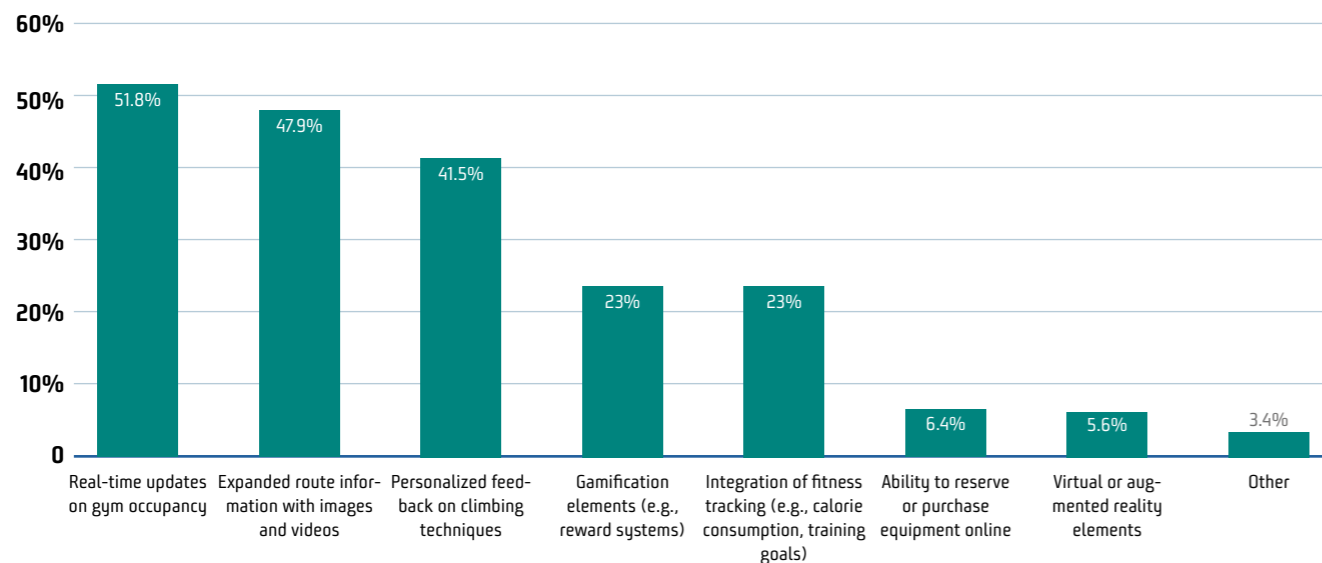

# ALL-IN-ONE GYM MANAGEMENT SOFTWARE FROM VERTICAL-LIFE

We know running a climbing gym isn't easy. Between managing staff, scheduling classes, handling payments, and keeping your climbers happy, there's a lot on your plate. That's why we have created an integrated software solution to help simplify your daily operations.

### ONE PLATFORM FOR ALL YOUR NEEDS

Instead of juggling multiple systems for point-of-sale, course bookings, staff scheduling, route setting, and customer management, our software brings everything together in one place. This means less time dealing with administrative tasks and more time focusing on your gym and your climbers.

### UNDERSTAND YOUR COMMUNITY BETTER

With all your customer data centralized, you can gain real insights into what your members want. Our Customer Relationship Management (CRM) tools let you see patterns in attendance, preferences, and engagement. This helps you tailor your offerings and communication to better meet their needs, building stronger relationships in the process.

### SAVE TIME AND REDUCE ERRORS

Automating routine tasks like payment processing and staff scheduling not only saves you time but also minimizes mistakes. Real-time reports show you how your gym is performing, so you can make informed decisions quickly.

### BUILT BY CLIMBERS FOR CLIMBERS

We're climbers ourselves, so we understand the unique challenges you face. Our goal is to provide straightforward, effective tools that make running your gym smoother, so you can spend more time doing what you love—whether that's climbing or helping others climb.

### WE'RE HERE TO HELP

We're committed to supporting climbing gyms like yours. If you'd like to see how our software can make a difference in your day-to-day operations, please get in touch or visit our website for more information.

Visit us: [gym.vertical-life.info](http://gym.vertical-life.info)

Get in touch: [gym@vertical-life.info](mailto:gym@vertical-life.info)

### WHO WE SHARE THE ROPE WITH



... AND 350 MORE GYMS



POS & PAYMENTS

# PAYMENT PROCESSING BUILT FOR GROWTH

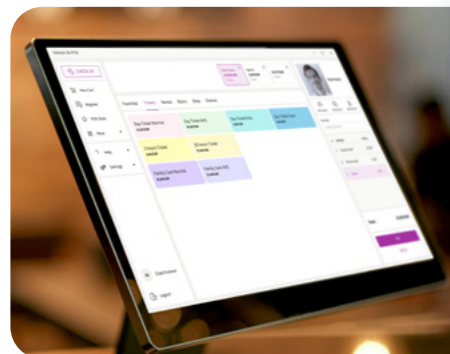

- Tickets
- Rental
- Courses
- Staff
- Analytics
- Routesetting

## SIMPLIFY YOUR BACKEND

Handle your most important management processes with a single, powerful, and integrated payment system. You'll see detailed statements of all transactions, including inventory purchases and rentals.

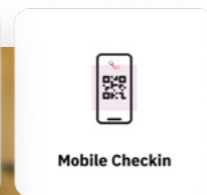
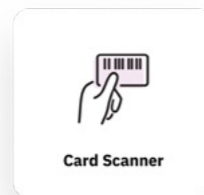

## SPEED UP CHECK-IN WITH FASTLANE TICKET SALES

Streamline the check-in process by using online registration with ticket sales. This makes both customers and staff happy while avoiding wait times at the counter.

From 10.11.2024 to 02.02.2025 · 16 lessons

**Beginner Climbing Course**

Total: **115,00 €**

[PAY NOW](#)

**Booked**

## OFFER CUSTOMERS MORE BOOKING OPTIONS

From mobile to web, we have easy booking options and payments for every device. Accept payments anytime, anywhere. Handle every sale on one system for quick & easy checkout.



## EVERYTHING FROM A SINGLE SOURCE

Our point-of-sale solutions, powered by the high-performance Windows IoT system, ensure smooth, secure, and fast transactions. With top-quality accessories included, you'll experience a fully integrated solution designed to optimize your workflow and reduce downtime.

## WELCOME TO THE WORLD OF MOBILE PAY

Save time and reduce errors with advanced ZVT interface. Our payment terminals accept all major debit, credit, and EC cards. The payment process and daily closing are seamlessly controlled through your point-of-sale system, ensuring faster and more accurate transactions.

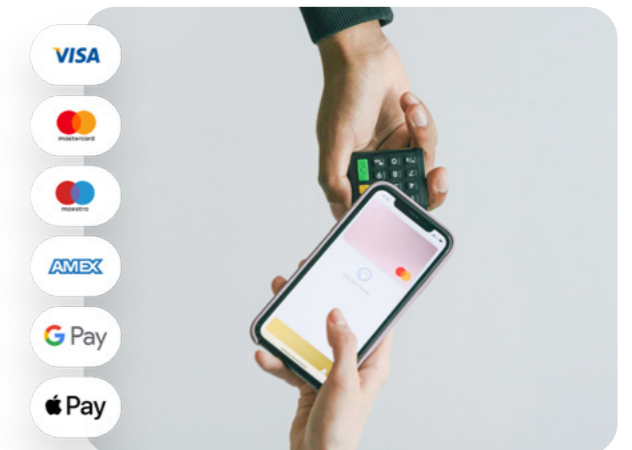

## REDUCE COSTS AND EXTEND YOUR OPENING HOURS

Operate your facility more efficiently by offering 24/7 access without additional staffing costs. Seamlessly integrated with Boulderado's doors, private rooms, or turnstiles, this system allows you to control access for customers around the clock. Whether for subscription holders or day-pass customers, it's the perfect solution to expand your service hours while keeping operational costs low.



GET A DEMO • [team@boulderado.eu](mailto:team@boulderado.eu) • [gyms@vertical-life.info](mailto:gyms@vertical-life.info)

**We'll show you how to:**

- » Manage your entire gym with an all-in-one platform, from bookings to route management
- » Engage your climbers with a custom-branded app and seamless course booking
- » Drive new revenue with easy-to-use tools for payments, ticketing, and more



## COURSE BOOKING

# EASY BOOKING, ANY WAY YOUR CLIENTS CHOOSE

From 10.11.2024 to 02.02.2025 · 16 lessons  
**Kids Climbing Course**

2 PARTICIPANTS

- LH **Lisa Hoffmann**  
Alpine Club member
- TH **Thomas Hoffmann**  
Alpine Club member

✔ **Booked**  
You will receive an email with course details

## BRING IN NEW CLIENTS WITH SIMPLE, MODERN BOOKING OPTIONS

Easily manage individual, group, and family bookings with our all-in-one system. Keep your schedule updated in real-time across your website and app, making booking effortless for you and your clients. Simplify operations while offering flexible options like kids' classes and group sessions for friends.

## YOUR BUSINESS, EVERYWHERE CLIMBERS ARE

Let your customers book courses anytime, anywhere, directly from their mobile devices. Share your public calendar, enable instant bookings, and manage registrations effortlessly, all in one place.

2/12 participants booked  
4 more required to reach the minimum

- LW **Lanzo Wolf**  
Booked on 25.10.2024 ✔ ▼
- JL **Jan Lang**  
Booked on 25.10.2024 ✔ ▼

Courses Shifts

**Add event**

Select course template:

- **Beginners climbing course** ▼
- ✔ **Payment is required for this course**

## CUSTOMIZE YOUR CALENDAR

Your calendar, your rules. Planning is easy with click-and-drag event creation. Easily categorize, price and share your courses through a public calendar link.

## COORDINATE STAFF WITH EASE

Easily assign the right staff to each course or task based on pre-defined roles and qualifications. Our dynamic system automatically adjusts staff numbers in response to booking demand, simplifying management and ensuring smooth operations.

**Fixed number of required staff**  
The course requires a set number of instructors, regardless of the number of participants.

**Participant based number of required staff**  
The course requires instructors based on the number of participants.

Assign staff:

Elisa Stark, Irma Lang ^

QUALIFIED

	<b>Elisa Stark</b> <small>max 40 h • Fixed</small>	14 h	340,00 €	✔
	<b>Irma Lang</b> <small>max 20 h • Fixed</small>	2 h	40,00 €	✔
	<b>Leon Jung</b> <small>max 40 h • Fixed</small>	6 h	150,00 €	

Follow up email

Going out 5 days after the end of the course

**Ready for the next step?**

Hi Martin,  
Well done completing the Beginners Climbing Course! Take things to the next level with our Climbing Progression Course.

**SCHEDULE EMAIL**

## BOOST CUSTOMER RETENTION WITH EFFECTIVE FOLLOW-UPS

Automate personalized follow-up and reminder emails for each course, driving repeat bookings and promoting your next offerings effortlessly. Strengthen customer loyalty by staying connected even after the session ends.

## ONLINE PAYMENT AND POS INTEGRATION

Reduce no-shows, and simplify your workflow by using our online payment services. And the best part: It syncs seamlessly with your POS. Get in touch now and we'll get you set up right away!

✔

**Paid**



## STAFF MANAGEMENT

# OPTIMIZE PERFORMANCE WITH BUILT-IN STAFFING TOOLS



**Route Setting Task Assigned**  
 You're tasked with setting routes in Upper Lead Area on 03.12.2024. ACCEPT

## TRACK HOURS AND PAYROLL

Decrease manual errors and ensure your team is properly paid. Let your software take care of clocking in staff, tracking hours, and calculating pay, tips, and commissions.

**Admin**

- Viewer**  
Can view on tasks
- Planner**  
Can manage calendar and checkins
- Admin** (checked)  
Can manage calendar, staff and checkins
- Super Admin**  
Can manage all

## EMPOWER YOUR STAFF

Offer open shifts, send job invitations and allow staff to manage their schedules with automated notifications.

**Leon Jung**  
Fixed contract • 32 h / week

**November 2024** Month Week

**32h** Total hours € 420 Total wage

LOG WORK

## CONTROL PERMISSIONS

Maintain discrete roles and responsibilities for each team member with assigned permissions. Hide or share sensitive information with managers, and add or remove staff right within your software.

## BUSINESS REPORTING

# MAKE DATA-DRIVEN DECISIONS, FASTER

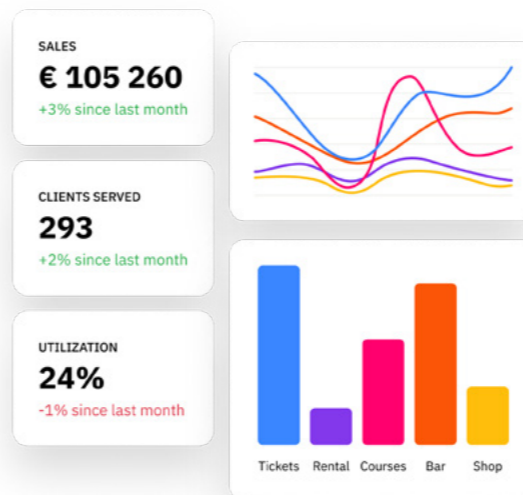

## DIG INTO PERFORMANCE METRICS TO UNLEASH BUSINESS INSIGHTS

Don't wait until the end of the month to fix what isn't working. See how you're doing today, this month, and this year so you know when and where to focus your attention.



GET A DEMO • [gyms@vertical-life.info](mailto:gyms@vertical-life.info)

### We'll show you how to:

- » Manage your entire gym with an all-in-one platform, from bookings to route management
- » Engage your climbers with a custom-branded app and seamless course booking
- » Drive new revenue with easy-to-use tools for payments, ticketing, and more





ROUTESETTING MANAGEMENT

# MANAGE ROUTESETTING AND KEEP YOUR CLIMBERS ENGAGED

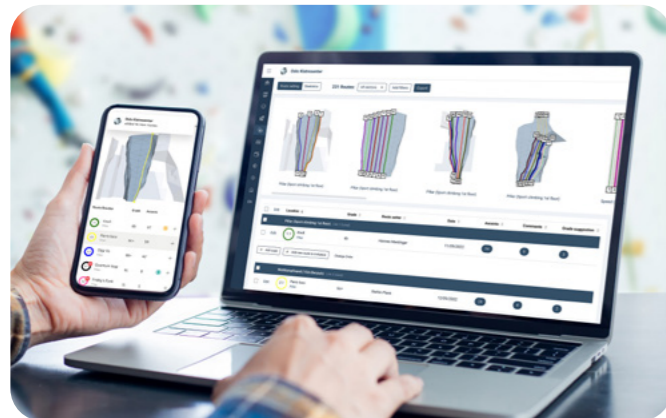

## CREATE A DIGITAL CLIMBING GUIDE FOR YOUR GYM

Empower your climbers with detailed, interactive topos. Easily create and manage a comprehensive digital guide for your gym, featuring route details, sector maps, and boulder information. Keep your routes up-to-date and accessible, all within the Vertical-Life system.

## MONITOR GYM ACTIVITY AND ROUTESETTING PERFORMANCE

Track your gym's popularity, route quality, and climb grades, while getting insights into your routesetters' performance. Use this data to continuously improve the climbing experience and optimize the quality of routes.

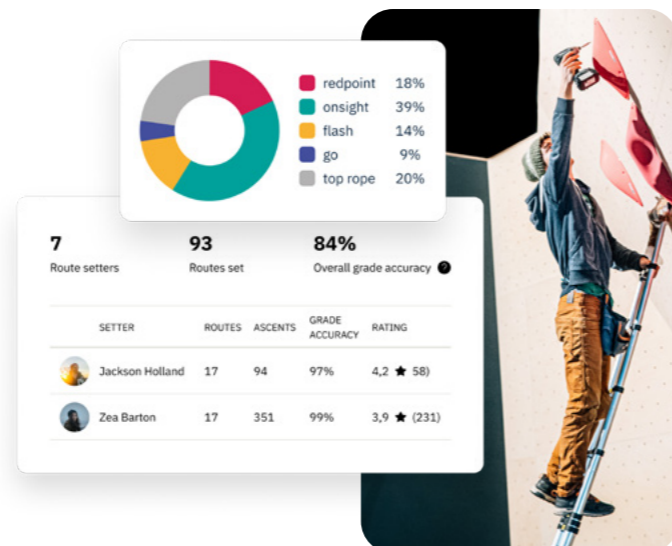

## PLAN ROUTES WITH EASE AND STREAMLINE STAFF COORDINATION

Analyze grade distribution across sectors to ensure variety in your gym's offerings. Easily plan routesetting sessions and invite staff members to collaborate, making sure your gym stays fresh and challenging for climbers.

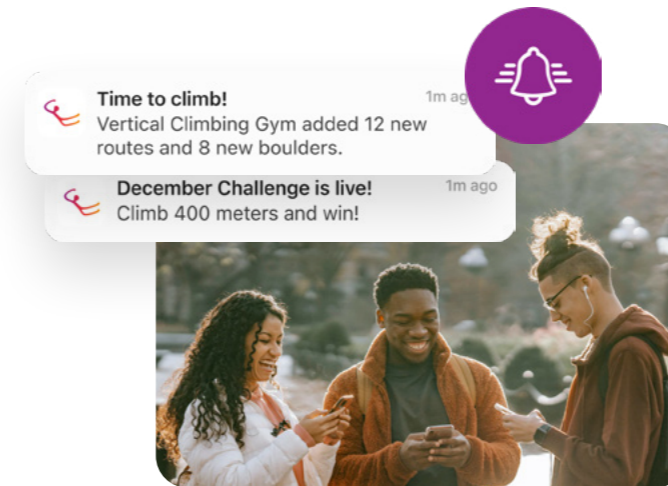
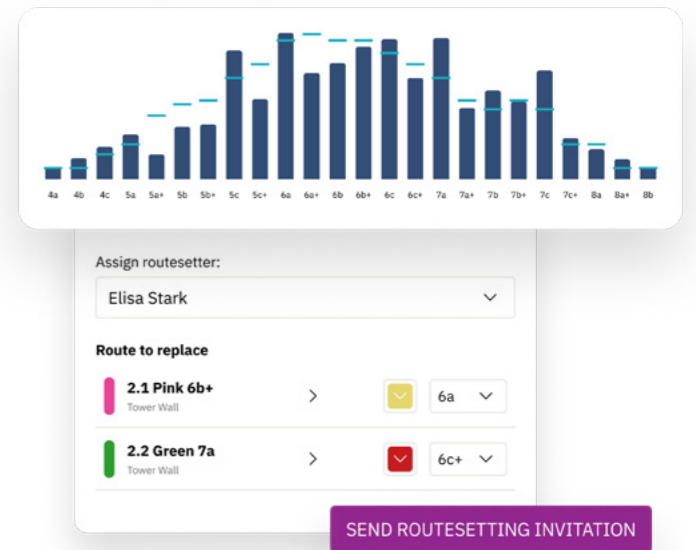

## ENGAGE YOUR CLIMBERS WITH REAL-TIME UPDATES

Keep your climbers informed with instant updates on new routes, challenges, and events in your gym. Receive valuable feedback from climbers to enhance their experience and keep your facility top-of-mind.

## DISPLAY LIVE ACTIVITY WITH ONSCREEN BROADCASTING

Show real-time climbing activity, route updates, and challenges on your gym's screens. Display general news, updates, and sponsored ads to keep climbers engaged and informed.

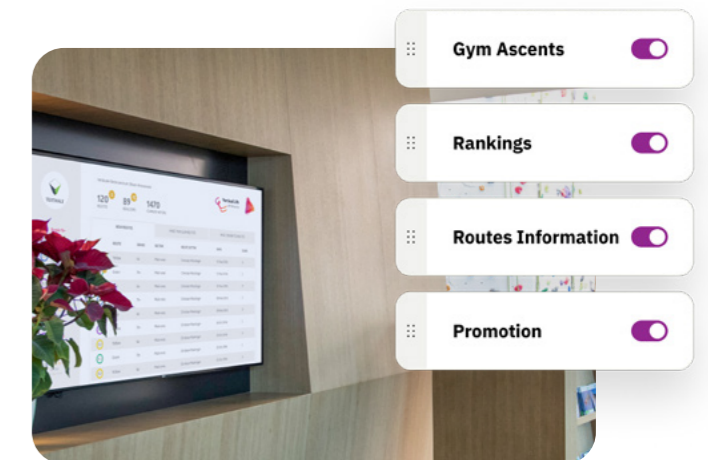

GET A DEMO • [gyms@vertical-life.info](mailto:gyms@vertical-life.info)

We'll show you how to:

- » Manage your entire gym with an all-in-one platform, from bookings to route management
- » Engage your climbers with a custom-branded app and seamless course booking
- » Drive new revenue with easy-to-use tools for payments, ticketing, and more



ROUTE CARDS

# UPGRADE YOUR ROUTE CARDS FOR BETTER CONNECTIVITY

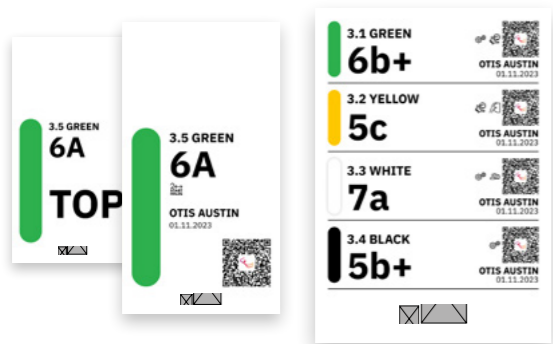

## CUSTOM TEMPLATES

Design route cards to fit your gym's brand, including logos, artwork, and take-down date options.

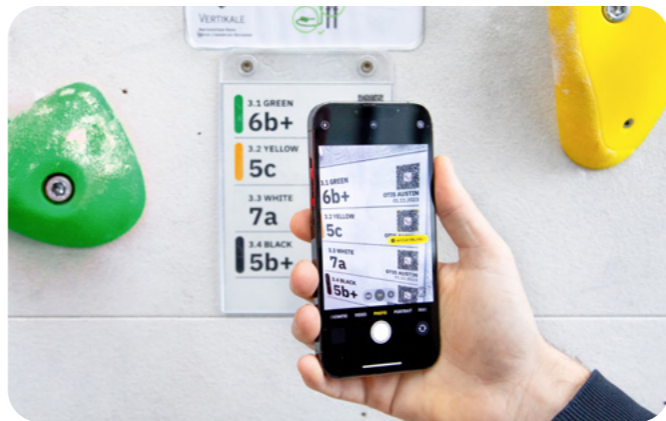

## EASY LOGGING WITH QR CODES

Climbers can log routes and view details instantly, while setters can update the database with ease.

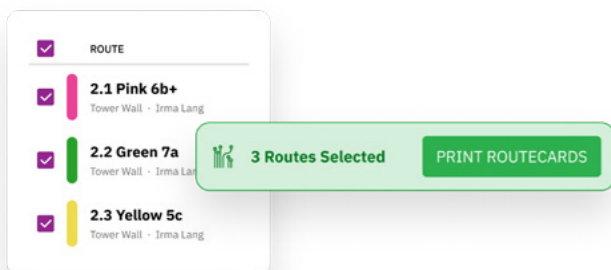

## STREAMLINED WORKFLOW

Simplify route updates and card printing, allowing setters to manage routes efficiently with just a few clicks.

## GYM CHALLENGES

# BOOST CLIMBERS' ENGAGEMENT WITH CUSTOM CHALLENGES

Create an atmosphere of friendly competition and community with tailored gym challenges. From leader-board rankings to real-time updates, keep your climbers motivated and connected every step of the way.

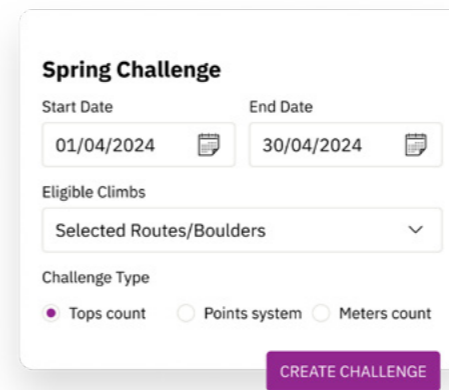

## CUSTOMIZE CHALLENGES TO FIT YOUR GYM

Set up challenges tailored to your gym's goals in just a few clicks. Choose whether rankings are based on meters climbed, tops completed, or points scored, and set the duration from a single day to a full month. Interactive gym topos make it easy for climbers to find and complete each route, boosting engagement across your community.

## STAY CONNECTED WITH YOUR COMMUNITY

Send direct messages and real-time updates to participants, keeping climbers in the loop and engaged throughout each challenge.

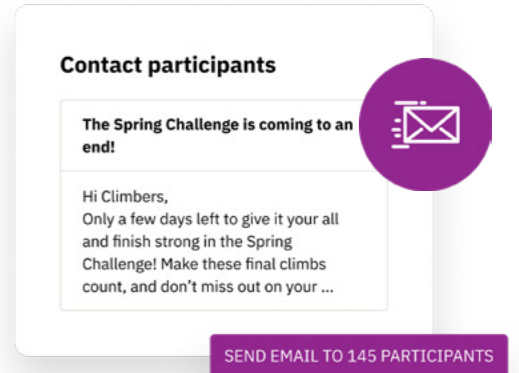



Vertical-Life

## VERTICAL-LIFE APP

# CONNECT WITH YOUR GYM COMMUNITY

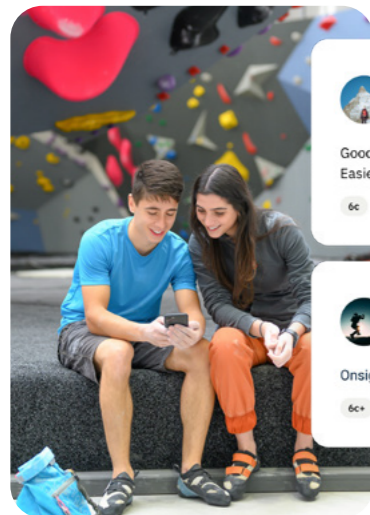

**Kristin Watson**  
Green 6c  
Vertical Climbing Gym

Good training for small jumps with rope. Easier for tall people.

6c Soft ★★★★★ 5 Nov 2024

**Simon Mills**  
Green 6c  
Vertical Climbing Gym

Onsighted, but it felt harder than a 6c

6c+ Hard ★★★★★ 5 Nov 2024

## COLLECT CLIMBERS' FEEDBACK

Empower climbers to rate and provide feedback on routes directly through the app. Use this valuable input to monitor gym activity, improve route quality, and enhance routesetter performance.

## COMMUNICATE UPDATES ON THE GO

Notify climbers when new routes and boulders are added. Keep them engaged and excited with real-time updates, creating a seamless, interactive gym experience.

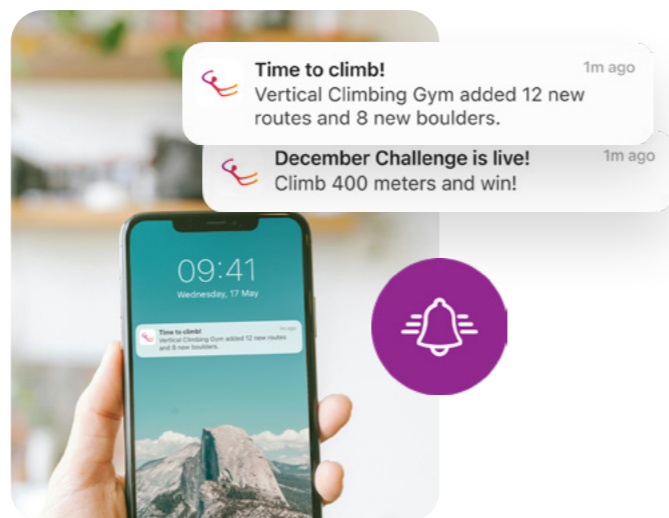

## SHOWCASE YOUR GYM WITH DETAILED TOPOS

Make navigating your gym easier with Vertical-Life's custom topos. Provide climbers with a full gym map, sector overviews, and detailed route and boulder information.

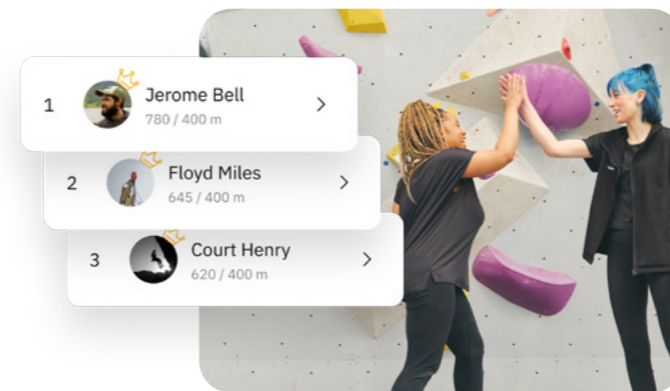
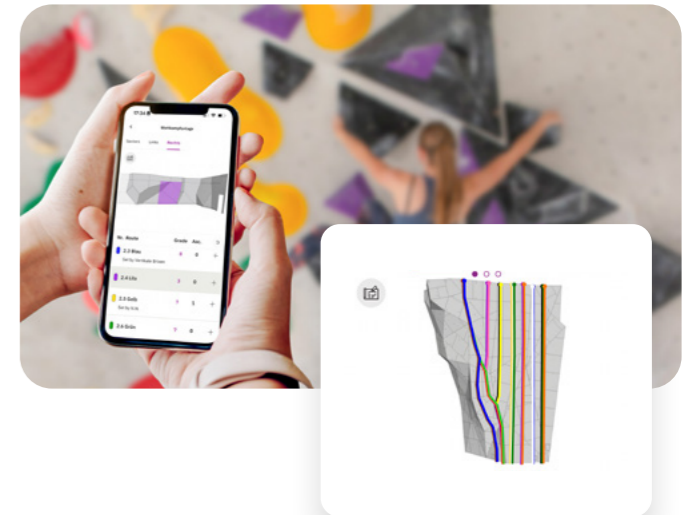

## MOTIVATE YOUR COMMUNITY

Engage climbers with monthly app challenges and friendly gym rankings. Climbers can track their progress, celebrate achievements, and compete with others. You can also create custom gym challenges to keep your community energized and connected.

## KEEP THE SENDS COMING WITH PERSONAL LOGBOOKS AND STATS

Give your climbers the tools to track their achievements with personalized logbooks. With every climb logged, climbers can monitor their progress, set goals, and stay motivated.

**Chad Erickson**  
Germany

146 Following 121 Followers FOLLOW

**6 ascents** 1444 pts · 95 m

**7b+** Hardest route

**6C+** Hardest boulder

6092 pts



DOWNLOAD THE APP AND GET IN TOUCH • [gyms@vertical-life.info](mailto:gyms@vertical-life.info)

### We'll show you how to:

- » Manage your entire gym with an all-in-one platform, from bookings to route management
- » Engage your climbers with a custom-branded app and seamless course booking
- » Drive new revenue with easy-to-use tools for payments, ticketing, and more



**RESULT SERVICE**

# COMPETITION RESULTS DELIVERED IN REAL-TIME

RANK	NAME	COUNTRY	1	2	3	4	5	6	7	8	9	10
1	Natalia GROSSMAN	USA	1	1	1	1	1	1	1	1	1	10
2	Oriane BERTONE	FRA	1	1	1	1	1	1	1	1	1	6
3	Mao NAKAMURA	JPN	1	1	1	1	1	1	1	1	1	13
4	Oceania MACKENZIE	AUS	1	1	1	1	1	1	1	1	1	7
5	Brooke RABOUTOU	USA	1	1	1	1	1	1	1	1	1	7

## REAL-TIME RESULT DISPLAY

Update scores live during the event through our intuitive interfaces. Judges, admins, and athletes can input scores directly, ensuring real-time updates. Display results dynamically on screens at the venue or stream them online via our API.

## PARTICIPANT MESSAGING TOOL

Message your participants at any time. You can notify selected participants about upcoming rounds, prize collection, and anything else via our flexible messaging tool.

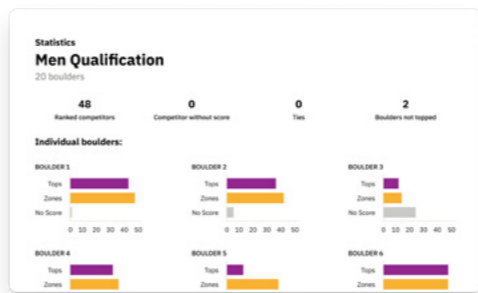
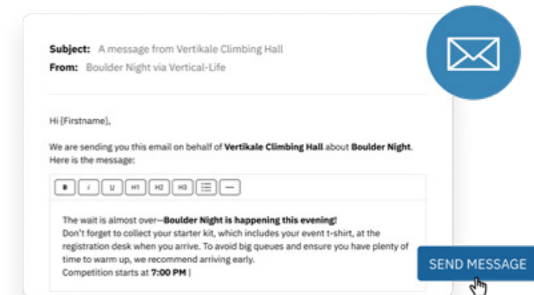

## ROUTESETTING STATISTICS

Take advantage of our event evaluation tools for all disciplines. You'll have all the insight you need to provide your setters with valuable feedback.

## OUR CUSTOMERS

The Vertical-Life Result Service is the most frequently used and relied upon scoring service for climbing competitions. It has been used at over 1,000 events, including IFSC World Championships, every World Cup since 2020, and hundreds of local events across the globe.



... AND HUNDREDS OF GYM COMPETITIONS WORLDWIDE

## SEAMLESS REGISTRATION AND PAYMENT

Choose from various registration workflows: let climbers register and pay directly through our platform with automatic invoice generation, or manage it manually via a simple CSV upload. Set participant quotas easily and manage your event with ease.

## CUSTOM FORMATS

Every event is unique, and so are your needs. Whether it's the number of rounds, categories, or scoring methods, our result service adapts effortlessly. Customize formats, rankings, and more to fit your exact requirements, ensuring a competition experience that feels truly yours.

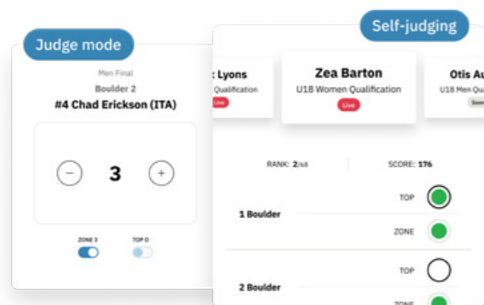
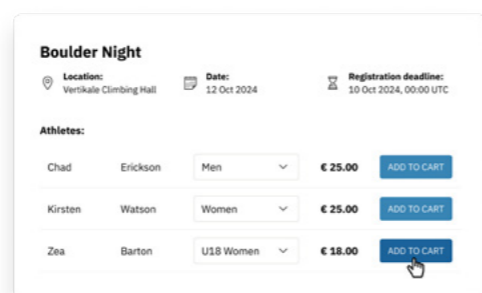

## EFFORTLESS JUDGING FOR EVERYONE

Our judging interface is designed for simplicity and efficiency, supporting offline capabilities to ensure seamless operation. Admins, judges, and athletes can easily interact with the system, keeping everyone informed and engaged.



**CONTACT US FOR A FREE DEMO AND EVENT SETUP**

Discover the benefits Vertical-Life Result Service can bring to your events.  
[sales@vertical-life.info](mailto:sales@vertical-life.info)



www.360holds.com

## EVERY DAY SOMETHING NEW. EVERY DAY SOMETHING 360.

More than just a climbing hold brand, 360HOLDS is a catalyst for change in the climbing hold world.

#Everydaysomethingnew is not just a slogan, but the real trajectory of 360s' daily operations and vision, whether it's route setting, shaping or product innovations.

The brand's journey, spanning over a decade, has been marked by **industry-leading achievements**, such as:

- » GRP-leading production,
- » Pioneering dual texture,
- » The iconic ghost pattern,
- » Route setting for the Red Bull Dual Ascent competition,
- » And route setting courses.

### ICONIC GHOST

Introduced in 2023 and available only for the Asymmetric line at first, the **unique GHOST pattern** quickly outgrew into the icon it is today. From its notorious debut in Hachioji Boulder World Cup to regular appearances in competitions and commercial climbing walls all over the world, the GHOST line is still turning heads and not looking to stop.

Now available in a spectrum of 14 colors, from classic best-sellers to some fresh shapes, the GHOST line is here to stay.

### EXCLUSIVE OFFER

Check out how to get a **free set of climbing holds** from 360 production!



SCAN ME

### Stay Updated!

Follow us on Instagram: @360holds  
For inquiries, contact us at: info@360holds.com

www.360holds.com

## DON'T MISS THE FRESH 360s!

### EVOLUTION BALLS

10 years after their first appearance, the iconic 360Ball is getting a revamp with an innovative flange and new dual texture. Choose from: high or low profile, full texture or dual texture, bolt-on or screw-on only.



### EDGY DISHES

- » Featuring our new innovative flange system,
- » Asymmetric and directional shapes for modern route setting,
- » Stacking options,
- » Flipped dual texture novelty.

### HERO POCKETS

From MONO to HERO! The Hero Pockets collection brings back the classic, challenging hold that climbers either love or fear... THE POCKET, but with a cool and modern twist.

- » Dual textured, super versatile, and comfy.
- » Available in all sorts of sizes, from the cozy one-pad mono to the perfect three-finger pocket, and even the amazing full-hand hueco.



## 360'S NEW PE PRODUCTION LINE

In order to meet all the needs of a climbing gym in one place, 360 production recently established the new PE production line alongside the existing GRP, PU, and plywood lines. The highest 360 production quality remains the standard. Highly abrasion-resistant and long-lasting when handled with care, the new PE material is already available for various brands

in 360's in-house portfolio, such as NEO, READY, LYNX, GOOD HOLDS, and of course, 360.

Everyone's favorite Juggy Balls line has now expanded with 160 new PE holds that perfectly complement the GRP and PU lines in both function and style.



**GOOD**  
Holds



[www.good-holds.com](http://www.good-holds.com)

## GOOD HOLDS. PURE JOY.

Straight from 360's new PE (polyester) production line, Good Holds are here to bring JOY to climbers of all levels and (dis)abilities.

Comfortable jugs and eye-catching shapes, Good Holds are made to handle the heavy traffic in gyms while keeping the price-performance ratio in mind.

The first line JOY is designed **with the needs of those who are approaching climbing for the first time**, promoting a safe and fun experience. From XL jugs to positive footholds and everything in between a setter needs to set an easy route or



### TIPS FOR ROUTE SETTERS: HOW TO SET AN EASY YET INTERESTING CLIMB

- 1. FOOHOLDS:** Adding extra feet will make easy climbs more accessible for all body types!
- 2. VOLUMES:** Volumes enhance easy climbs and help beginners learn wall movement. Pay attention to fall zones!
- 3. PLAY:** Keep it interesting and play with combinations—small footholds with big handholds, or big footholds with small handholds.
- 4. SAFETY:** Still remember how you felt as a beginner? Fear levels and ability to fall are different for beginners!

**NEO**



[www.theholdsgallery.com](http://www.theholdsgallery.com)

## NEO - FROM SHINING IN COMPETITIONS TO EVERYDAY COMMERCIAL USE

Korean by origin, shaped and produced in Slovenia, NEO is a brand that reflects this double citizenship with one wide line that greatly **serves elite competitions and everyday commercial setting needs alike**. From slick NO TEX shiny macros to high-grade PE and PU grips, NEO is a brand where style has brilliantly met function.



### COMPETITION

One shape 3 textures:

- » All texture
- » Dual texture
- » No texture

Neo Absolutes macros are perfect for modern route setting with their low profile, hidden grip, and surprising no texture.



**To the right:** No tex macros for all the route setters who love to spice things up with some shiny and slippery stuff.

### COMMERCIAL

With over 200 shapes, from XL jugs to XS-sized footholds and everything in between. Available in PU or PE ... the choice is yours.





[www.simplvolumes.com](http://www.simplvolumes.com)

## SIMPL - PLYWOOD VOLUMES REDEFINED!



Simpl stands out. Always and by choice. **Born with the desire to move away from the concept of wooden volumes as mere angle changers or attachment surfaces for holds.**

Simpl. volumes are designed to be the star of the show for several reasons:

- » Pioneering an innovative use of dual texture,
- » Built to last,
- » A big catalog with classic and unconventional shapes,
- » 5 different textures to choose from.



### ONE CATALOG - 5 TEXTURES - ENDLESS COMBINATIONS!

- » **DUAL TEXTURE:** Classic SIMPL dual texture with a white shine that makes Simpl stand out.
- » **ALL TEXTURE:** Full texture for those looking for a (more) Simpl option.
- » **COLOR ONLY:** No texture, perfect for the big angle changers or when there is no need for texture. Available in all 14 Simpl colors.
- » **TRANSPARENT with FULL TEXTURE:** For an elegant wood-only finish. The high-quality friction and attention to detail SIMPL is known for, with a (more) Simpl look.
- » **TRANSPARENT and NO TEXTURE:** For an elegant wood-only finish, but no texture. Even (more) Simpl!



### COLLAB WITH WIDE BOYZ – NEW CRACK SYSTEM UNLEASHED!

What happens when Wide Boyz CRACK expertise meets the SIMPL engineering masterminds? One of **the most versatile and complete crack systems** comes to life!

After months of development, it's been put through the real test at the Verzasca Dam project. The SIMPL x Wide Boyz **Crack Generator** is now ready to meet fissure aficionados all over the world.



## LYNX, WHERE GEOMETRY MEETS INNOVATION



[www.theholdsgallery.com](http://www.theholdsgallery.com)

Born in Germany, produced in Slovenia. With a catalog that spans from **plywood volumes to GRP macros and blurs the lines between the two**, LYNX holds distinguish themselves with geometrical shapes and offer a unique mix of function and aesthetics. Oh, and have we mentioned the **extensive PU and PE options?**

**NEW REBEL WOOD LINE: UNIQUE BOTH FUNCTIONALLY AND AESTHETICALLY**  
Light, low profile, and subtle, they succeed in creating a fluid and organic climbing experience that highly contrasts with the precise geometrical outline, inviting setters and climbers alike to fill the space in between holds with their creativity.



# READY

## ALWAYS IN STOCK, ALWAYS READY TO GO



Ready holds made a name for itself thanks to **lightning-fast delivery times, high-quality GRP**, and an extensive family of shapes with an unmistakable outline.

The famous **Ready outline is now back with a brand new series of shapes in PE and PU**, to build up and expand the original line, where the needs of incrementally busy climbing walls are met. **One outline, endless variety of grip types** and the route setting throughout all styles has never been easier.



[www.theholdsgallery.com](http://www.theholdsgallery.com)

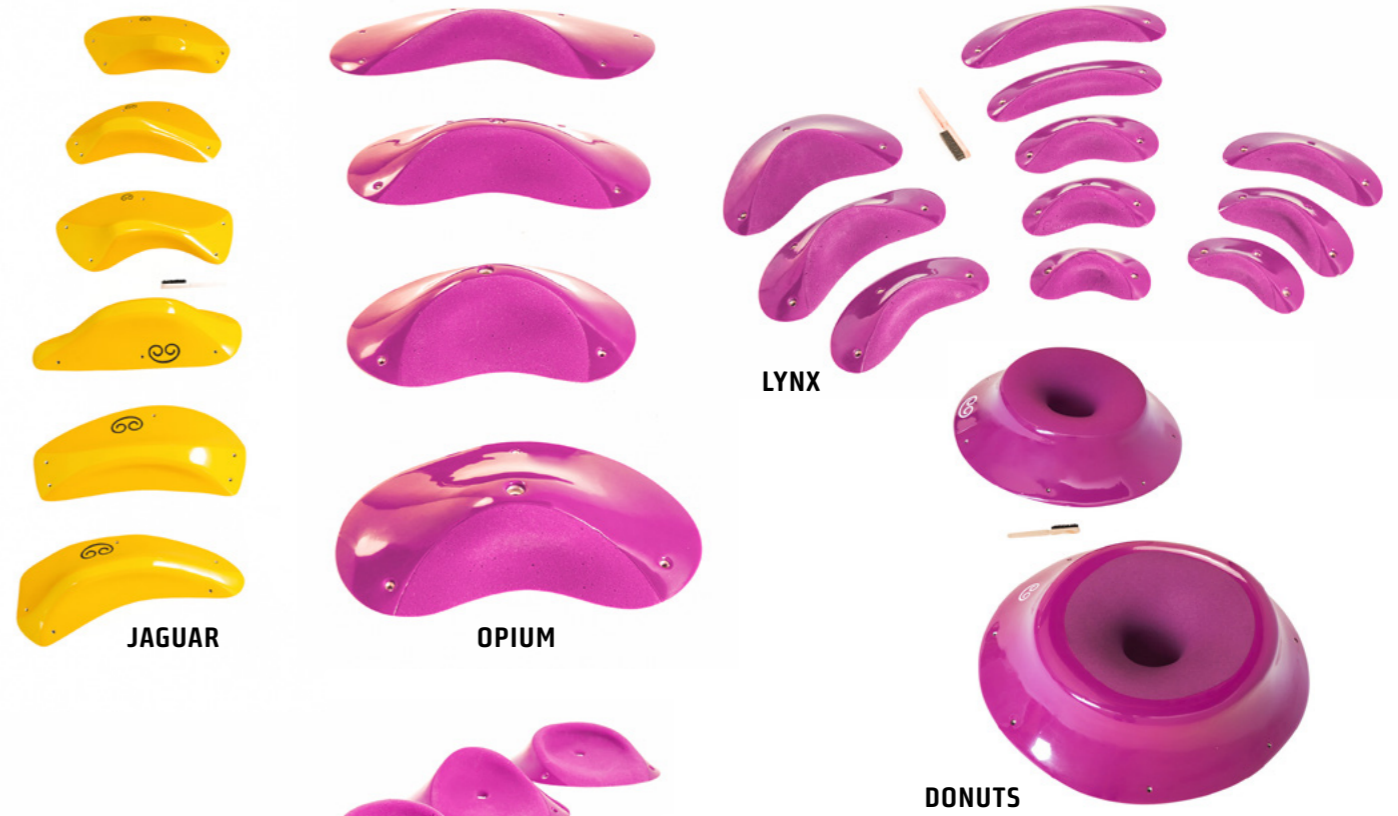

# AGRIPP

## THE PASSION OF CLIMBING



With 30 years of experience and a constant presence in all international competitions, including the Olympic Games and the World Cup, Agripp is a leading brand.

**OUR VALUES ARE CLEAR:**

- » Premium quality and finish: We are committed to offering top-of-the-line products (quality, finish, and durability).
- » Fast deliveries thanks to stock availability on all continents.
- » Committed brand: We collaborate with factories on all continents to reduce the carbon impact of transportation and are working on prototypes made from recycled plastic.
- » Satisfaction guaranteed: If you are not satisfied with your purchase, we will fully refund you without hassle or complex procedures.

**VOLCA**



**DELTA**



**FUZE**



**FENIX**



**ASTON**



**RAIN**



**NINJA**

**MANGA**



**SHARK**



The new PU Dualtex range for 2025 includes 32 holds, along with 24 new macros. Additionally, a new E-Shop will launch in November, alongside the release of our 2025 catalog.



### GROUNDWELLS

Embark on an adventure of limitless possibilities with the Groundswells Full Set, a meticulously curated collection comprising **37 climbing holds**. Crafted to elevate your climbing experience, this comprehensive set is a testament to innovation, versatility, and ergonomics.



## MADE FOR SETTING

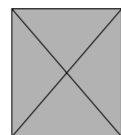
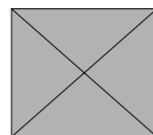

Inspiring routesetters through high-quality climbing holds poured from Aragon's industry leading polyurethane. Our shapes were designed with a focus on ergonomics, creativity, compatibility, and aesthetics. We want to provide routesetters with the tools to leave climbers with a memorable and positive climbing experience. Our mission is to produce timeless shapes that inspire routesetters to think outside of the box and push routesetting into the future.



### RIPPLE EFFECT

Introducing the Ripple Effect, a versatile set of fiberglass macros perfect for any commercial gym or competition wall. **12 macros** in the set, available in both full texture and dual texture options, these macros offer a wide range of possibilities for all levels of route setters.

The Ripple Effect macros come in a range of sizes, from small to extra large, ensuring there's a perfect fit for every move you are trying to create. Each macro is meticulously designed to be slightly incut, with flangeless attachment for the entire set.

Crafted from reinforced fiberglass, these macros are built to withstand all types of climbing, offering durability and longevity. The design of the Ripple Effect macros adds a visually appealing element to any climbing wall, enhancing the overall climbing experience.

Whether you're setting a challenging bouldering problem or designing a technical route, the Ripple Effect macros offer endless possibilities. Enhance your climbing wall with the Ripple Effect and experience the versatility and durability of these exceptional macros.



### CARBONS

The Carbons, our revolutionary dual-textured climbing holds that offer unmatched versatility and control. These holds are designed to be both bolted on and screwed on to the wall, providing maximum flexibility for routesetters and climbers alike. Full set contains **48 undeniably beautiful holds**.

The Carbons feature a sleek and geometric shape that not only adds a visually appealing element to your climbing wall but also ensures a comfortable grip. Crafted with precision, these holds are designed to fit perfectly in your hand, allowing for confident and secure holds during your climbing sessions.

What sets The Carbons apart is their dual-texture design. The strategically placed dual texture provides routesetters with unparalleled control over the placement and usage of the holds within boulder problems or routes. The different textures allow for creative and dynamic climbing experiences, challenging climbers of all levels to adapt and find the best grip and technique for each hold.

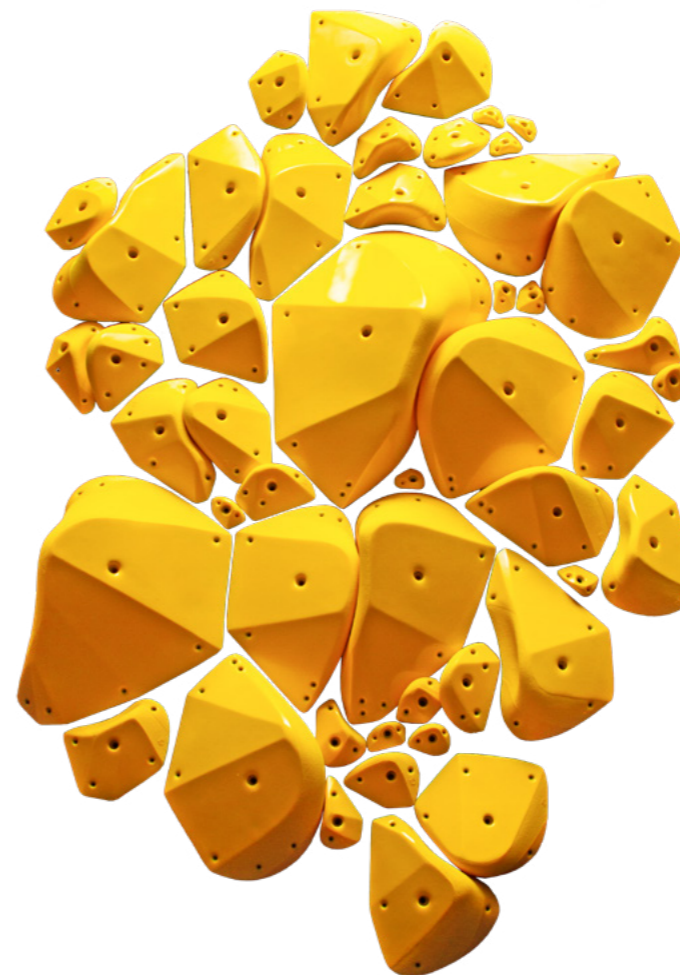



# SHAPE THE MOVEMENT

[www.cheeta-holds.com](http://www.cheeta-holds.com)

Founded by renowned international setter and shaper Laurent Laporte, who has been a key figure in the climbing industry since the 1990s, Cheeta has established a global reputation for high quality. Its products are recognized worldwide, making Cheeta an essential partner for prestigious international climbing events. Constantly pushing the boundaries of innovation and design, Cheeta introduces new shapes, unique product combinations and cutting-edge materials.

From the very beginning, Cheeta's mission has been to provide setters the tools to craft original routes and boulders, blending creativity, new movements, and aesthetic appeal.

#ShapeTheMovement.

## SOFT PU CATEGORY

Discover our 85 holds in soft PU, these holds offer a softer texture for the skin while maintaining excellent friction. Perfect for climbers of all levels, these holds provide enhanced comfort during extended sessions and are built to withstand heavy use on high-traffic routes and boulders. Available in all our colors



**Stadium:**  
52 comfortable medium size jugs.

**Lift:**  
22 good holds from L to XXL

**Odyssey:**  
40 varied holds from jugs to slopers

## NEW HYBRID CATEGORY

We are proud to introduce this new category of product. We decided to combine the best assets of each material (PU, fiberglass or wood) and create a new category.

### LINK HYBRID

Link Hybrids are designed to host surface-mounted holds, solving the durability problems of fiberglass and PU products that are damaged by wood screws. Each hold features a PU base and a replaceable wooden plate equipped with T-nuts. Designed to take up minimal space, Link Hybrids offer great versatility by allowing setters to break up profiles and create diverse angles. With multiple combinations, they enable precise movement adjustments. Available in 12 different versions with different shapes, inclinations and sizes.

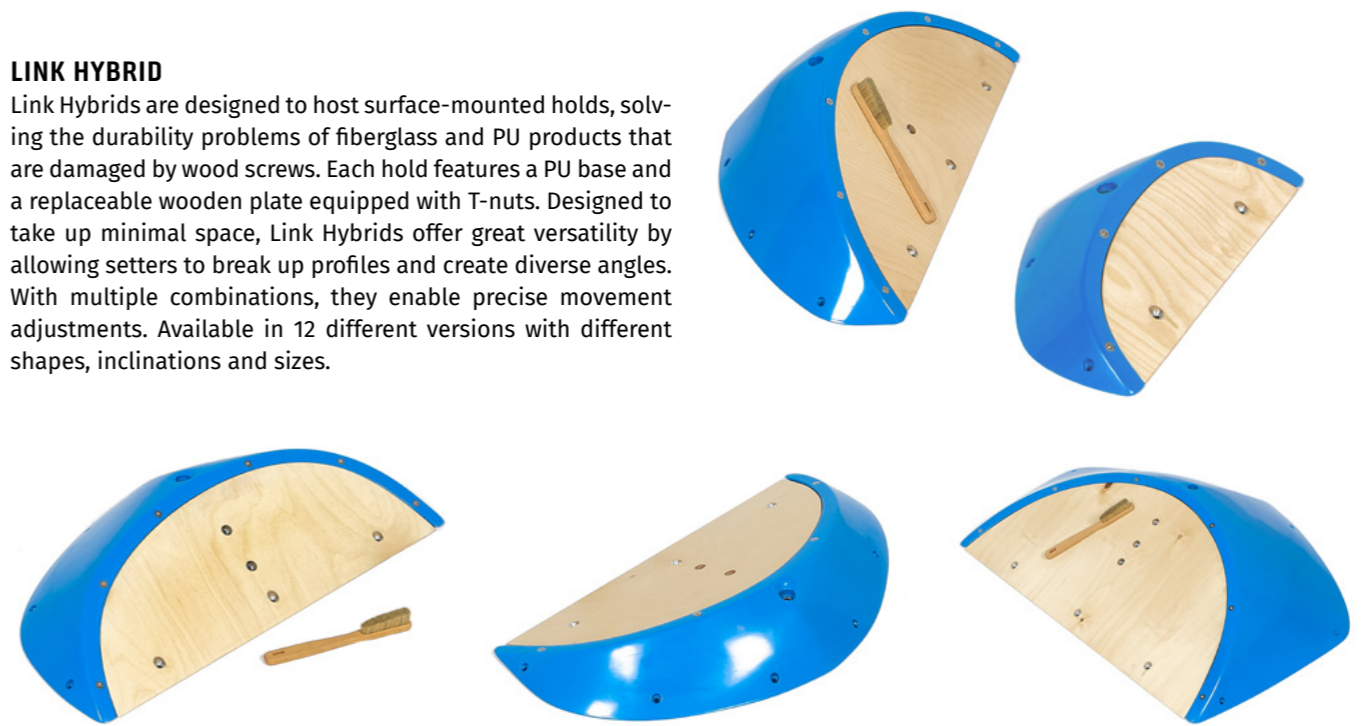

### SKY-BASE

Rediscover the iconic Sky-balls, now lighter, featuring a dual texture and interchangeable wooden panels. We've also introduced a new fixing system, eliminating the need to screw into the base when stacking the pieces. Available in two versions—low profile and steeper—these options can be stacked together, allowing for versatile combinations of steep and low elements.

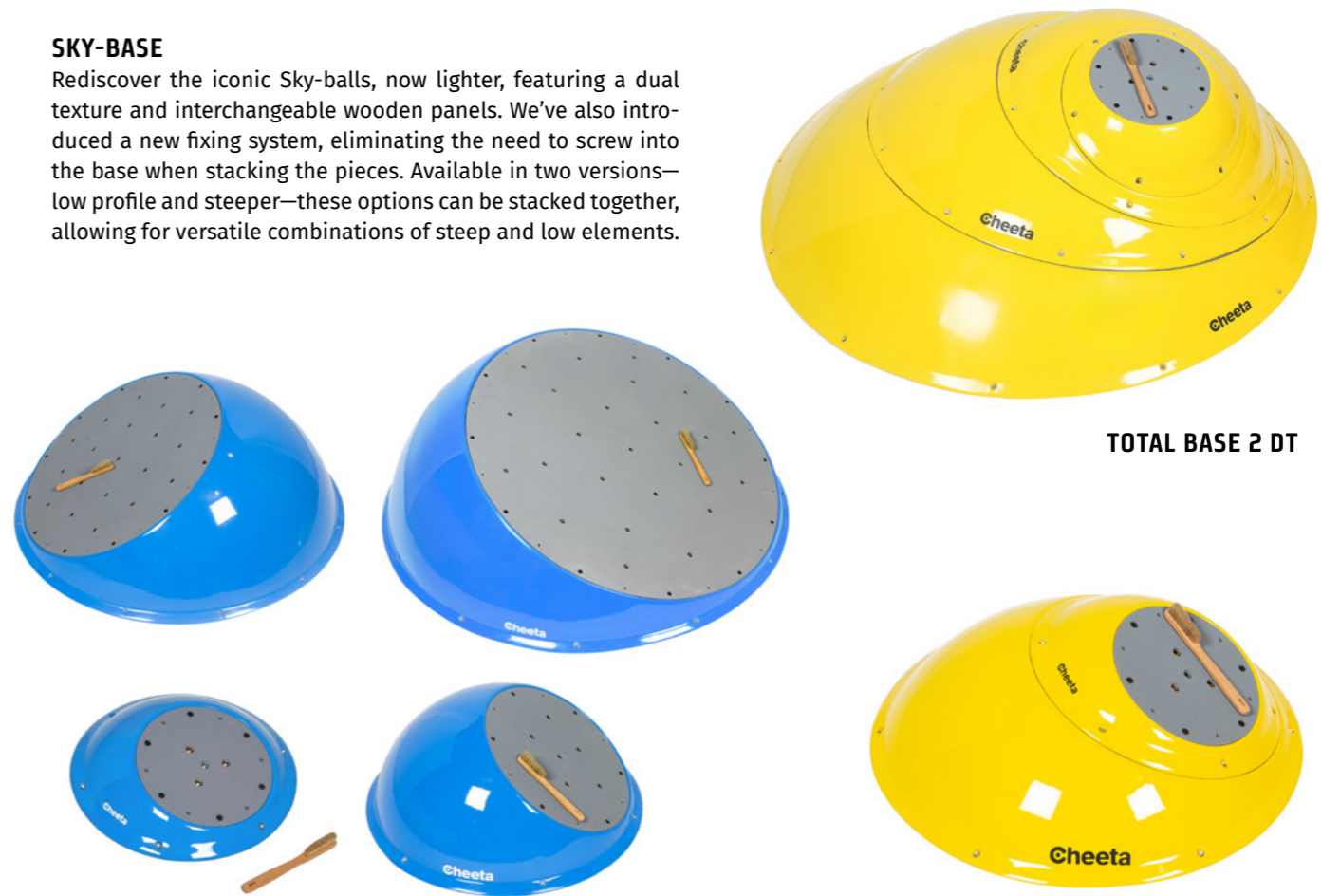

**TOTAL BASE 1 DT**

**TOTAL BASE 2 DT**

**BASE 2 DT SM**

## ODYSSEY RANGE

These ergonomic holds and macros are ideal for Fontainebleau-style compressions, delicate balance sequences as well as creating dynamic moves with ease. Challenging to hang onto and exert force, but perfect for expressing creativity through movement.

### ODYSSEY FIBERGLASS

Explore our wide range of 17 fiberglass volumes, from XS to L, from slopers to jugs. Each volume is ergonomically designed and emphasizes the concept of compression, ensuring you find the perfect piece to enhance your boulder or route.



### ODYSSEY PU HOLDS

This range of 32 holds became quickly a classic from Cheeta, especially for the screw-ons and MEG holds. All in dual texture.



## STADIUM RANGE

Crimps, slopers, or jugs, this range always provide ergonomic precision and directional control. A wide range, perfect for both gyms and competitions.

### STADIUM PU HOLDS

From the tiny XS crimp to the expansive MEG sloper, this collection of 114 holds allows you to design visually appealing routes with a wide variety.



### STADIUM FIBERGLASS

10 medium sizes volumes, from sloper to jug. Ideal for coordination moves, thanks to the double edge shape that makes bouncing smooth. Available in full or dual texture.



## NEW PLYWOOD VOLUMES

### SILEX

Our brand-new 24-volume series offers numerous options for creating huge 3D coffer on profiles with many variations. Some are angular, others very flat. DT or Full texture. Up to 3m high and 45cm high, but don't worry, since they're made up of 3 pieces, storage and assembly remain easy.

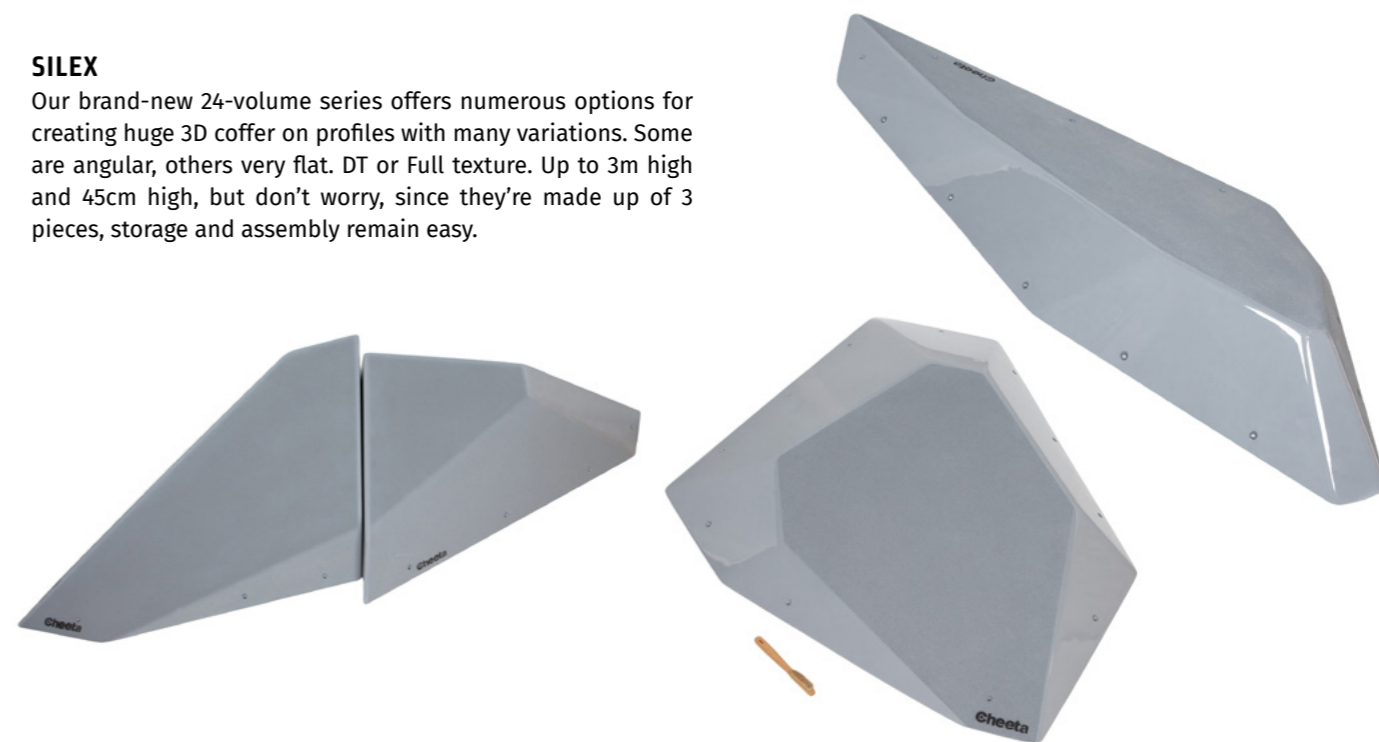

### ASYMMETRIC PYRAMIDS

This selection of seemingly innocuous little pyramids turns out to be highly effective for adjusting every movement. The variation in size and angle, combined with the judicious use of dual texture, make this a weapon for every setter.

tion in size and angle, combined with the judicious use of dual texture, make this a weapon for every setter.

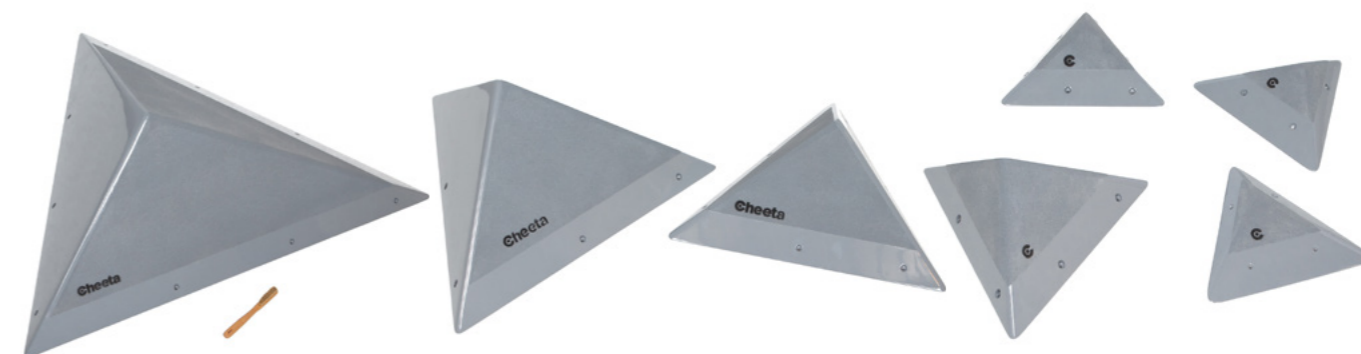

### ALL-TIME CLASSICS, NOW IN DUAL-TEXTURE

Some shapes are so efficient that they become timeless. Such is the case with the wood volumes that have made Cheeta's reputation and been a source of inspiration for many. You'll

now find our revisited DT versions for even greater precision in your setting.





Photo: Thibault Debelle

## VERTEX DESIGN: AESTHETICS AND FUNCTIONALITY IN CLIMBING

Vertex Design was established in 2016 with a clear vision for future development. Our holds and macros are thoughtfully designed for the needs of climbers. Vertex Design's primary goal is to achieve optimal functionality while aligning with modern climbing trends and embracing the aesthetic beauty and harmony of form.

The clean, structured designs and diverse range of grips and combinations empower route setters to create countless climbing routes with ease.

### DUALISM

The latest line in Vertex PU holds called Dualism appeared as a necessity of our designer to create a continuation of the macros in PU grips. This is also the main line and direction in which the vertex continues to work. The brand manage to create holds and volumes that combine perfectly together for more exciting climbs.



### MASTODONT

We present some of the latest models of grips and volumes. The line of macros Mastodont continues Vertex's search and aspiration to create first and foremost a functional product designed for climbers who want to develop in climbing adequately. While at the same time vertex brand seeks for a recognizable look and identity in their shapes. The first noticeable in Vertex

products is meticulous attention to detail and the high quality of the product. Mastodont corresponds with other shapes and lines of the brand and thus route setters can create not only functional and challenging climbing but also homogenous and precise routes.





# E-SPACE HOLDS & VOLUMES

## EXPLORATION AT THE HEART OF OUR DNA

Space-holds is all about passionate climbers and designers. Climbers, route-setters, shapers, we explore new shapes and grips every day. We imagine movements that will give you the pleasure of climbing and discovering new sensations.

Since 1992, we've passionately pursued our creativity, bringing together different worlds to invent new holds and volumes that are immediately tested in our climbing gyms in Grenoble.

Attentive to new uses, we have embarked on an eco-friendly development approach in line with new environmental challenges, to invent the urban climbing of tomorrow.

**E-WOOD**  
New wood volumes are made of resin-coated wood or Dual Texture. They come in different shapes or sizes.

### BAKERY

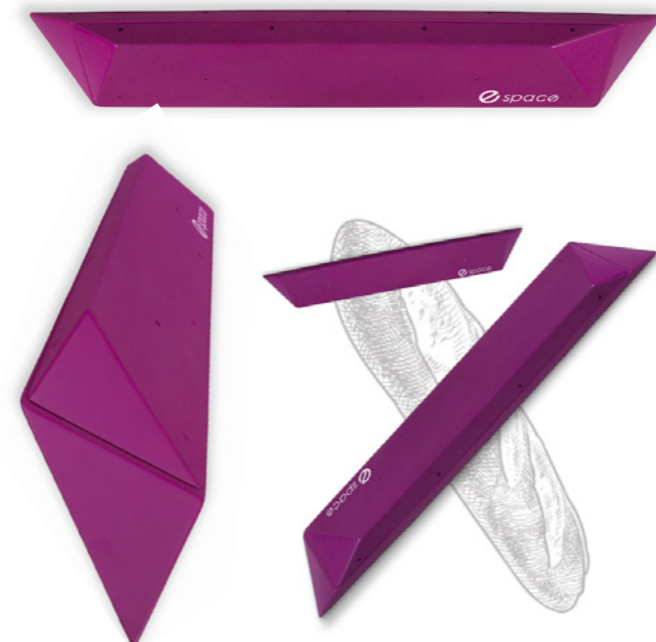

### ANIMALS



### E-SERIES

The E-series are Espace's latest innovations and flagship series. Aesthetically pleasing and ergonomic, they have been developed for the purpose of graceful climbing.

This category reflects the brand's culture of exploration. With new concepts and materials, each collection has its own universe of inspiration to offer route-setters and climbers unique experiences.

### NO WOOD



### KRAKEN

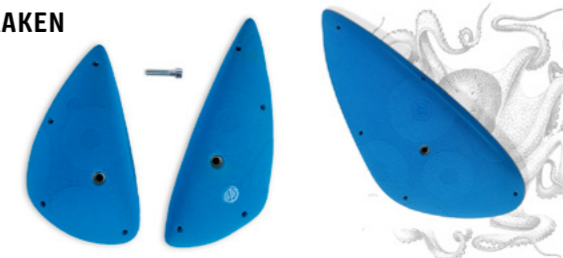

### HELMET

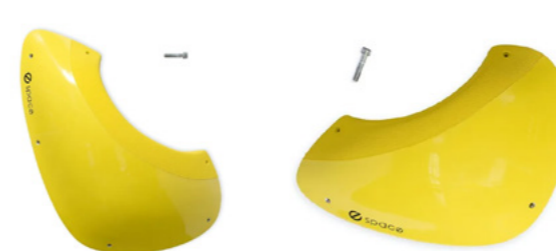

### CARVING



### RHINO



### CUBES



# Unique Shapes



artline  
Holds

## A NEW DIMENSION FOR ARTLINE VOLUMES



### VORTEX, THE NEW WAVE

The curves and signature edging are reminiscent of rolling and breaking waves. Used as edges, slopers or crimps for those with nimble fingers, Vortex holds are available in GRP and PU, and either full texture or dual texture.

Vortex 1-5 FT



Vortex 6-9 DT



Vortex M3 PU with Ultimate grip technology



Vortex 9-11 DT



### MERCY – HARDER, FLATTER, STRONGER

The Artline range that has definitely had the biggest impact! This iconic shape can be found in gyms all over the world.

Created in 2019, the Mercy XXXL and XXL were among the first fibreglass macro holds.

In 2022, they became available in XS, S, M and L sizes, as the first recyclable thermoplastic holds.

In 2025, they're back with a flatter shape, with dual texture featuring strongly.



Mercy XXL 6-10 DT



Mercy XXXL 6-10 FT

### ARTLINE RAISES THE VOLUMES STANDARDS

Over the last 10 years, the movements used in climbing have evolved considerably. Volumes are largely responsible since they allow setters to add relief and play around with angles and slopes. In light of this (r)evolution, we took a fresh look at our volumes range.

With the bar being set ever higher in climbing, we also revised and raised our standards

- » Dry and soft touch
- » Uniform grain
- » Shiny dual texture
- » Improved lifespan

www.artline-holds.com

Flat Triangle



Ramp



Squamid

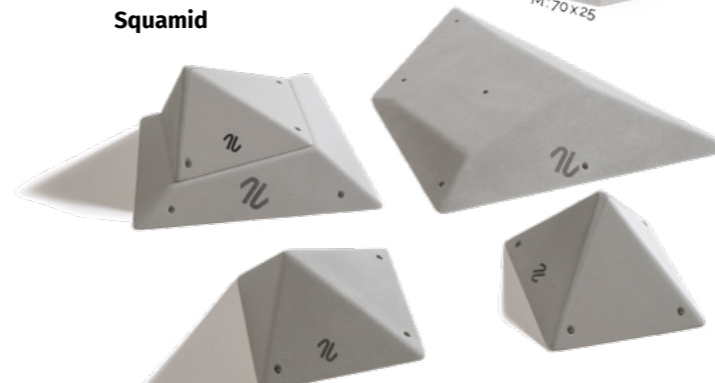

Triamid

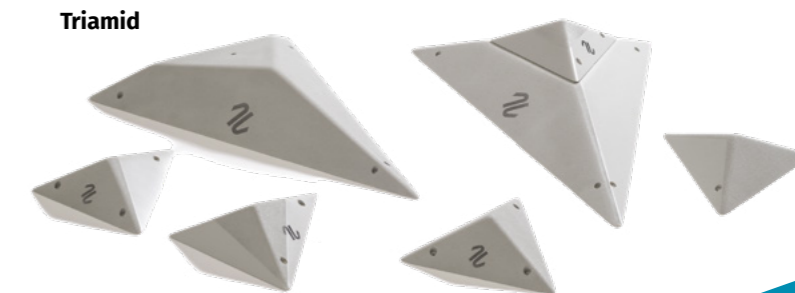



# POLYTALON – CLIMBING HOLDS MADE IN GERMANY



POLYTALON provides the perfect fusion of creativity, engineering, reliability and a pinch of madness. If you are looking for modular and ergonomic shapes with a special haptic and really innovative design, we are happy to assist you to fulfil your vision of a diverse climbing and setting experience. Our PU sets are carefully selected and manufactured in Germany, with focusing on each and every demand. Functionality, durability and sustainability first. Our shapes are mostly directional, easy to combine and clean, with an aesthetic outline for outstanding, still space-saving designs. These shapes are ready to help you easily create modern climbs, from easy to comp, from boulder to lead.

And even more important: All the holds are tested according to DIN 12572-3: To ensure the greatest possible safety for your customers, setters and walls.

For more information, feel free to contact us: [info@polytalon.com](mailto:info@polytalon.com)  
And stay tuned on our social media channels: [@polytalon\\_climbing](https://www.instagram.com/polytalon_climbing)

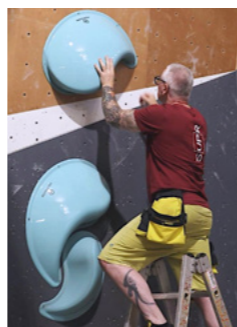

### MACRO YINGS

The Ying Macros not only catch the eye with their gentle curves, but above all encourage new and even more versatile movements. The Macros are made from very light and recycled plastic. This makes them easy to handle and kind to the environment. Break-out-proof metal inserts for the fixing screws also ensure that you will have fun for a very long time.

They match the Ying PU series by shape and colour-wise. Consequently, there are no limits to the imagination for highlight and comp-style bouldering or even massive lead routes.



### PLAYFUL - FUNNY - INCUT

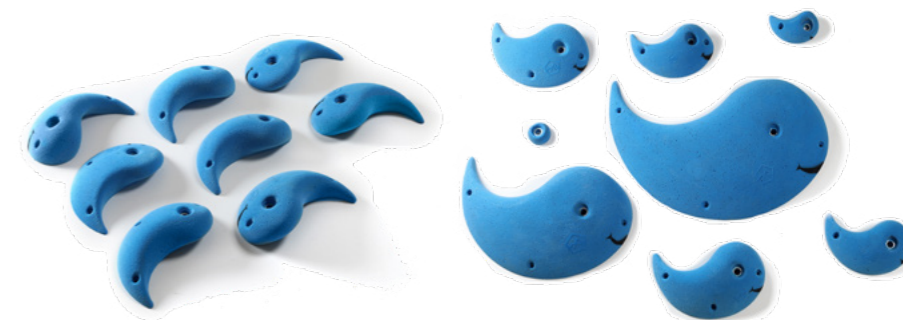

### MOBY - KIDS CLIMBING HOLDS

This series was specially developed to make new entry into climbing more fun and attractive. The friendly, appealing look motivates young and old and also feels safe when climbing thanks to the deep incuts. Another advantage: Thanks to the directional shape, the first sequences of movements can be playfully integrated into beginner tours. This line will make your newbies addicted and offers an ideal spring-board for higher levels.



### STACK - ADAPT - MOVEMENT



### MELON

Round wood volumes? Only for Comps? Not anymore. With our new Melons we make this powerful "angle-changer" accessible for commercial gyms! Add a dimension to your wall and offer new possibilities to your customers and route setters. Medium sized from 30 to 50 cm wide. Nice extra is the PU series that fits perfectly on the volumes. Also check out the one and only prebent screw-ons, specially designed to be screwed on the round mantle of the 100% wood volumes.

### BAT FAMILY - THE CLASSICS



### WAVEGUIDE - NEW SERIES 2025

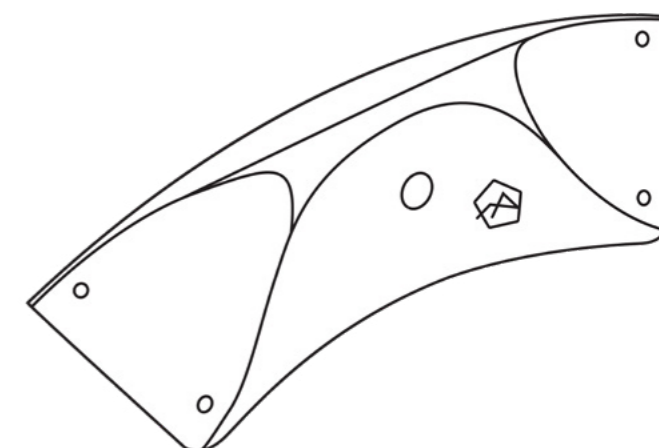



**VACUUM THERMOFORMED MACROS**

New Vacuum Thermoformed Macros from Kilter and Urban Plastix are light, strong, clean, and available in a variety of colors from Binary Production in Canada and Absolute Production in Colorado.



**KILTER** by Ian Powell and Haptic by our pro setters/shapers design team. Over 5,600 grips in PU from Aragon and Composite-X, New VTF Macros, Kilter Boards, Customizable Spray Walls, Frames and Pads.

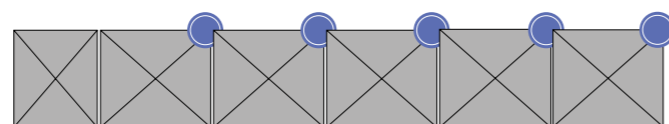

**URBAN PLASTIX**

Popular PU series from Peter Juhl including expanded Stealth Dual-Tex, Regs, Ditches, Waves, and Stratos, plus new VTF made at Absolute and Binary! 2,155 holds and counting.

**NEW URBAN PLASTIX VTF MACROS**

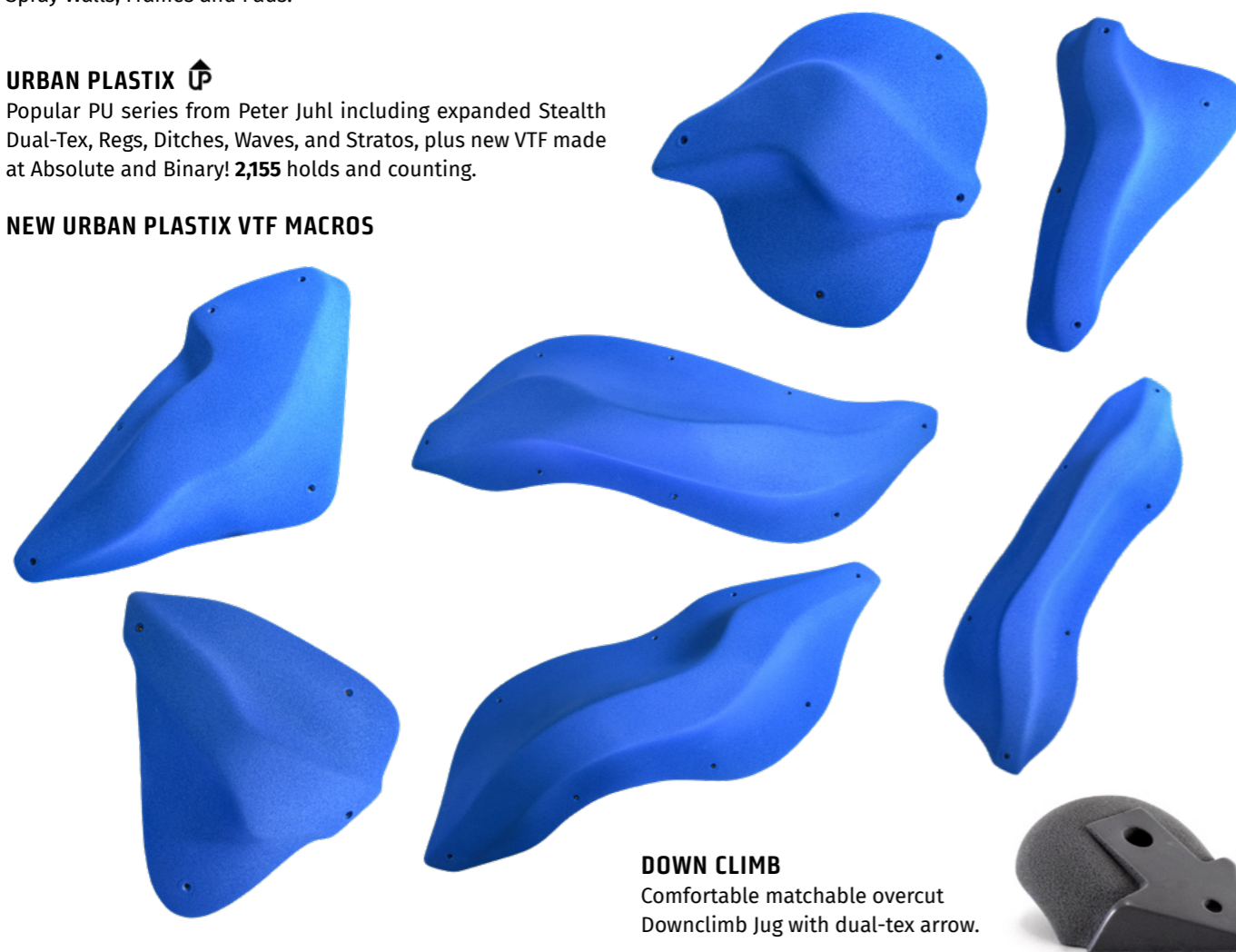

**DOWN CLIMB**  
Comfortable matchable overcut  
Downclimb Jug with dual-tex arrow.

**ADJUSTABLE FRAMES**

**Adjustable Slabs:** 24' x 14'-16', -10° to 40°

**Adjustable Steep Walls** with overhanging kickboard: 16' x 16' 35° to 70°

**Adjustable Kilter Boards:** 0° - 70° all sizes from 16' x 12' down to 7' x 10'. Freestanding and bolt-down options available.

**Ask us about bundle pricing and packages!**



CLIMBING HOLDS  
MADE FROM  
**RECYCLED AND  
RECYCLABLE  
THERMOPLASTIC**

LONG-LASTING  
TEXTURE FOR  
HIGH-TRAFFIC GYMS

ADAM ONDRA  
PROLINE



Photo: Petr Chodura

**THERMOPLASTIC**  
DURABILITY + SUSTAINABILITY

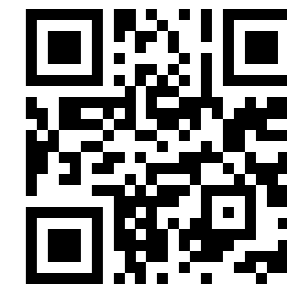

**B2B ACCESS FOR  
PROFESSIONALS**

SPECIAL PRICING  
EXCLUSIVE OFFERS  
FAST SHIPPING  
(3-15 DAYS)

EXCEPTIONAL  
CUSTOMER SERVICE

**EUROHOLDS** YOUR  
RELIABLE PARTNER

[www.euroholds.com](http://www.euroholds.com)

Photo: Petr Chodura



PLYWOOD VOLUMES  
THERMOPLASTIC MACROS  
WOODEN HOLDS  
PU HOLDS





# BaRocka WALLS AND MATS

The history of BaRocka's climbing walls dates back to 2016. Since this day we have created many boulder gyms, rope climbing walls, school walls and kid playgrounds. Our biggest realization is Skarpa Bytom with over 2300 sqm of climbing surface - the biggest climbing object in Poland.

Our projects are always dedicated to a specific place where the climbing panel will be located. The individual elements are adapted to the parameters of the facility and needs of the client. Each project is preceded by a 3D visualization and follows the latest trends in the design of climbing walls. We provide boulder and rope climbing walls, colorful walls for kids, and boulder mats.

## WHAT MAKES US SPECIAL

### PANELS

- » smooth friction or without friction,
- » transparent or half transparent colors,
- » reduced shoes marks
- » UV stable,
- » easy to clean,
- » Self centering T-nuts with 4mm initial diameter without thread for bolt centering. Special coating for outdoor use.
- » Edges protection with stainless steel stripes - very durable but with low visual impact,
- » Top edge jug- made of two round edges plywood, makes a nice hand hold on the top of a boulder wall.

### MATTING

Made of 3 layers of foam, carpet cover with PVC base cover. Our mats are well absorbing fall impacts, but still keeps stiff surface, that is easy for walking and vacuuming



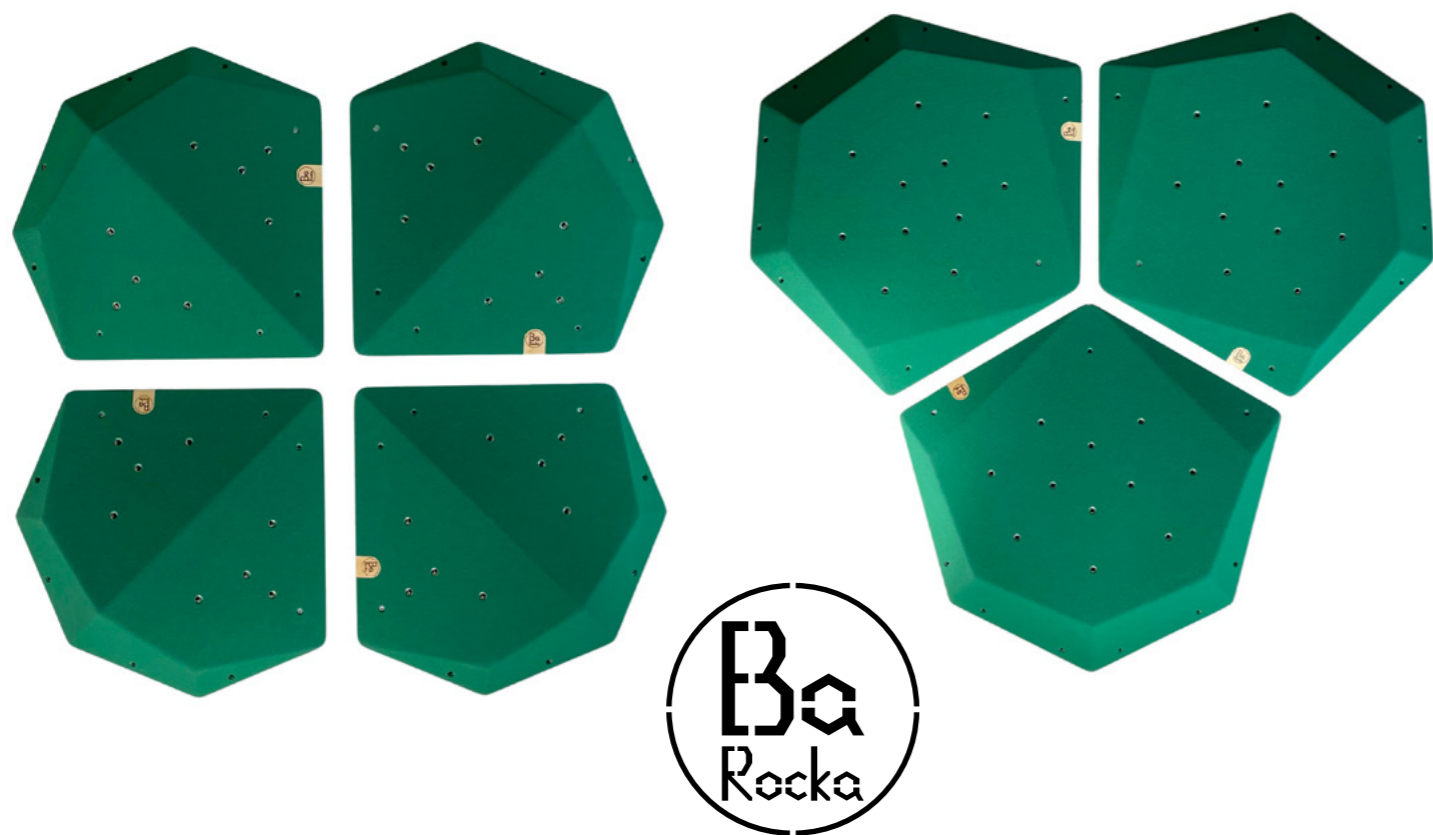

# BaRocka

## PLYWOOD VOLUMES

BaRocka volumes from years are well known in the climbing industry. Volumes are very durable, skin friendly and easy to clean. All sockets are self centering t-nuts. This year we have expanded its variety of shapes and sizes of volumes, up to over 300 models. Soon all models will be available in several sizes. We also improved the design of structures and assembly methods, which makes the products much more durable and safe. In 2024 BaRocka developed a professional, comprehensive strategy to become a more environmentally sustainable company. Our goal is to keep emission and waste to a minimum.

### CLOVER

The CLOVER set consists of 6 stackable matching pieces. All this in six sizes, up to 1,8 m wide.

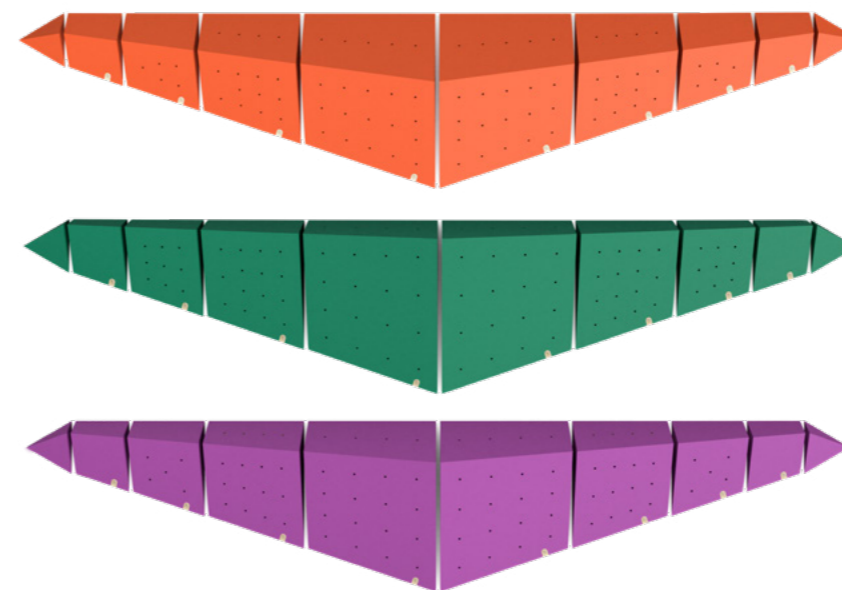

### WINGS

Wings sets available in 3 angles which define the height of the ramp. Length of two sets (left and right) is 606cm!

### CRACK

Crack set consists of 10 elements. Thanks to the extensions, you can make a crack as long as you wish.



### DUALTEX

There is also a new design of transparent dual-texture, that shows the beauty of natural wood!



BRINGS CLIMBING  
*to everyone*

We build the canvas...  
**YOU CREATE THE ART**



OFFICIAL SUPPLIER

Official Partner  
since its creation in 2007

[www.epclimbing.com](http://www.epclimbing.com)

## TITAN: THE GAME-CHANGING OFFICIAL BOULDER WALL

TITAN is the **first standard competition boulder wall designed in collaboration with the IFSC and top route setters** to challenge climbers globally.

Its diverse angles and versatility bring a new level to competitions and training. Now available worldwide, climbing gyms can offer internationally recognized routes, giving climbers everywhere access to world-class challenges.

With TITAN, the future of competitive climbing starts here.

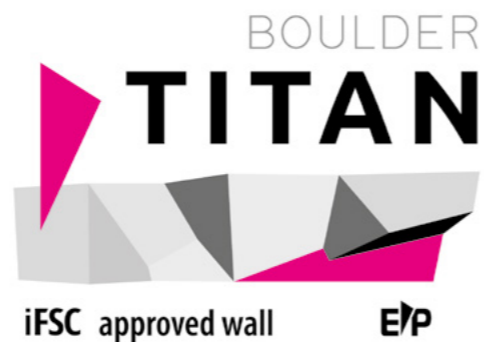

Photo: Lena Drapella / IFSC



Photo: The Climbing Lab

To learn more about the Titan, watch our YouTube series featuring Percy Bishton, Garrett Gregor, and Mickaël Mawem!



## 57 NEW MINI HOLDS TO COMPLETE OUR MACRO RANGE!



Made from recycled and **100% recyclable** materials, these mini holds seamlessly match our Macro range, providing route setters with a complete and cohesive set, perfect for creating diverse and challenging routes.

Check our catalogue!





## ADVENTURE & ENTERTAINMENT

www.citywall.eu

Citywall is all-in-one climbing solution provider, with over 25 years of experience in designing top-quality climbing gyms & walls and all other climbing related accessories (indoor and outdoor). As Europe's leading manufacturer, with more than 500 unique projects, we're a trusted and reliable partner in the industry worldwide. Our products meet the highest EN 12572 safety standards, ensuring reliability, sustainability and quality in every project.

Our exciting adventure & entertainment concept is designed to bring creative climbing experiences to a broader audience (families). Perfect for climbing gyms, adventure parks, shopping malls and any other sport facilities, this innovative approach seamlessly blends fun and safety, creating an engaging environment for everyone.

## CITYMAT

We understand that safety is essential in any climbing environment. That's why we specialize in providing top-quality safety mats - designed to offer maximum protection for all climbers. We offer durable PVC mats for high-traffic areas and carpet-covered mats for a softer landing and better aesthetics. Both options are customizable to fit the needs of any climbing facility, providing optimal protection and comfort.

**Adjustable walls** have not only transformed the climbing industry but have also become a must-have training equipment for every climbing gym! From affordable DIY entry-level setups to fully professional installations (7x10, 8x12, 12x12 and 16x12).



Safety mats for kids (next to Labyrinth).

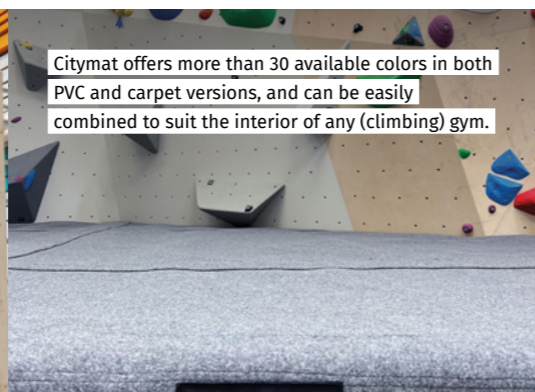

Citymat offers more than 30 available colors in both PVC and carpet versions, and can be easily combined to suit the interior of any (climbing) gym.

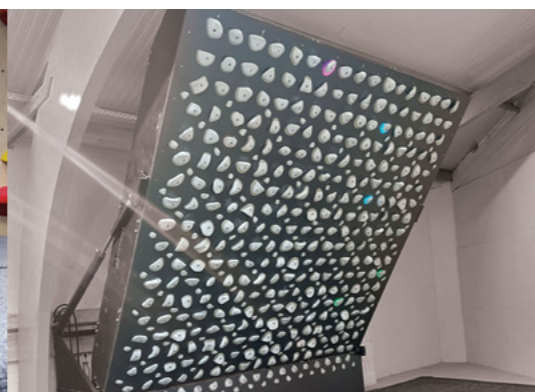

Citywall adjustable walls are Certified.

## Illusion



BRING WORLD-CLASS CLIMBING TO YOUR GYM.  
 TRAIN WITH ILLUSION.



10  
 MACROS

### NOCTURNAL PINCH

The Illusion - Nocturnal Pinch macro collection delivers superior hold adaptability, supporting various climbing techniques. Available in a variety of 10 sizes and shapes.

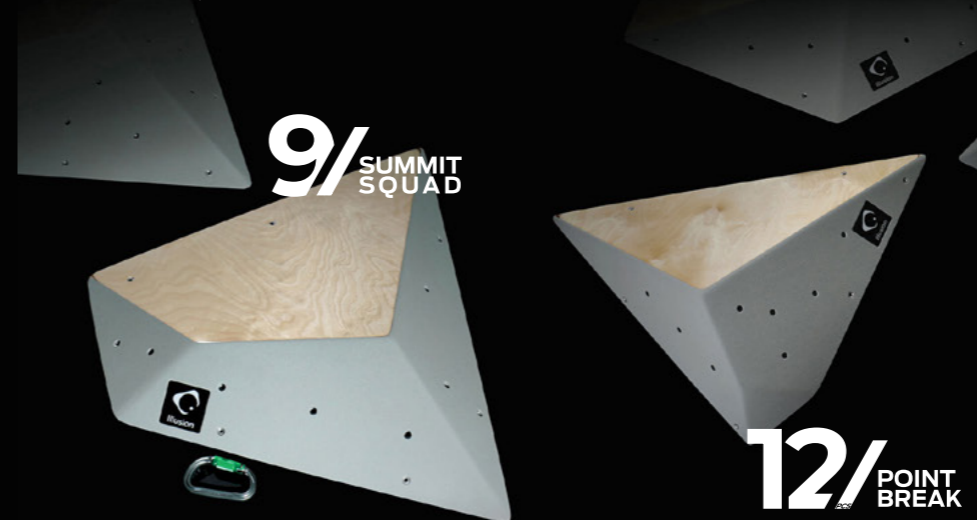

9/  
 SUMMIT SQUAD

12/  
 POINT BREAK

Two brand new Illusion nature-inspired geometrical volume collections: Point Brake (DT): 12 pieces (9 with DT), Summit Squad DT: 9 pieces. Both collections are available from small to giga sizes, with a stackable option. A must-have pieces for every modern climbing gym.

## INFINITY



RABBIT HOLES DT

Challenge yourself with the new Infinity Rabbit Hole DT (Dual Texture) collection! Available in 14 sets.



## CLIMBING GYM HEAVEN

ONE STOP SHOP SPECIFICALLY FOR ROUTE SETTERS & GYM OWNERS

VOLUMES  
 MACROS  
 HOLDS

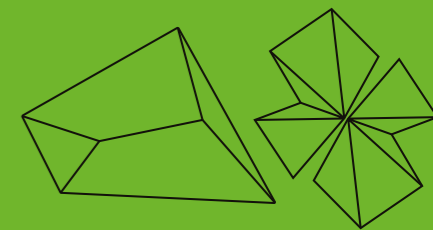

800+  
 PRODUCTS

VISIT US:  
[ClimbingGymHeaven.com](http://ClimbingGymHeaven.com)



DAV Boulderhalle Garmisch Patenkirchen 2024



## **BOULDERING GYM DEVELOPMENT, DESIGN & CONSTRUCTION**

[www.benkyclimbing.com](http://www.benkyclimbing.com)



Boulder Island Mannheim 2024

We've been climbers for years, both as passionate enthusiasts and professional competition climbers. At some point, we found ourselves in need of high-quality matting for bouldering gyms.

That's when we embarked on a journey over 20 years ago to develop our patented Benky matting, designed to fit all possible needs. As our expertise grew, we ventured into becoming gym owners.

Now, with our extensive experience and keen design sense, it was only natural to take the next logical step: building climbing walls.

### **BENKY CLIMBING WALLS**

Benky Climbing walls are designed and crafted to the highest standards. We ensure seamless joints and use top-tier coatings as standard practice.



Bouldre Terminalen Tromsø 2022

## **BENKY CLIMBING MATTING**

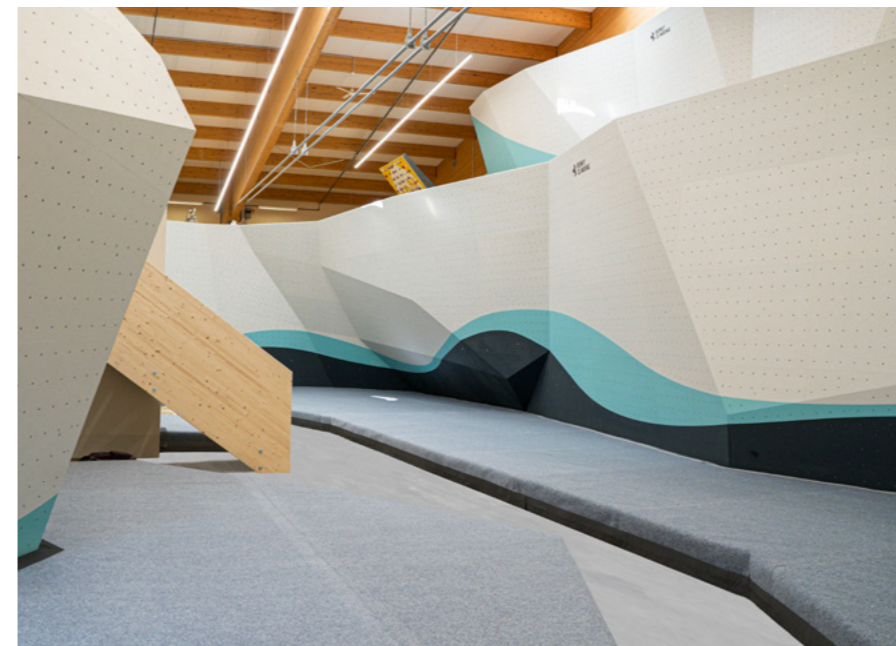

### **PREMIUM GERMAN-MADE BOULDERING MATS**

Our state-of-the-art manufacturing technology ensures perfectly tensioned carpet surfaces, guaranteeing a completely flat and wrinkle-free installation.

We offer a dustproof version of bouldering gym carpets as well - not only to simplify the cleaning process during vacuuming, but also to prevent chalk from penetrating deep into the carpet. Goodbye to chalk accumulating under the carpet which is released into the air with every jump onto the mat, and hello to cleaner air. An added bonus: this also greatly increases the lifespan of your foam.

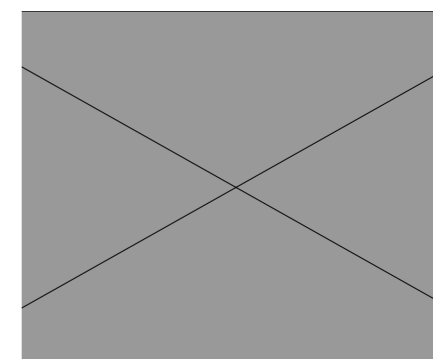



## GYMCARE SERIES

### GRIPWASH

Benky Gripwash was developed specifically for cleaning climbing holds. Soaking holds in Gripwash quickly and effectively removes rubber, chalk, sweat, and more, without leaving a smeary residue - perfectly restoring their original surfaces. All while being eco-friendly and saving water. Certified and made in Germany for a sustainable



### SKUNKX

Our SkunkX hygiene spray is tailored perfectly for rental shoes, but works on any damply treatable surface. Apply it once, wait one minute and let air dry - thanks to its much higher concentration of alcohol than comparable products it dries faster and kills more bacteria. Faster, cleaner and a pleasant citrus aroma to top it off.

### RUBBERX

Tired of rubber stains on your wall and matting? RubberX solves the eyesore - simply apply, let soak, brush lightly and rinse it off. The only product of its kind, developed by gym owners for gym owners.

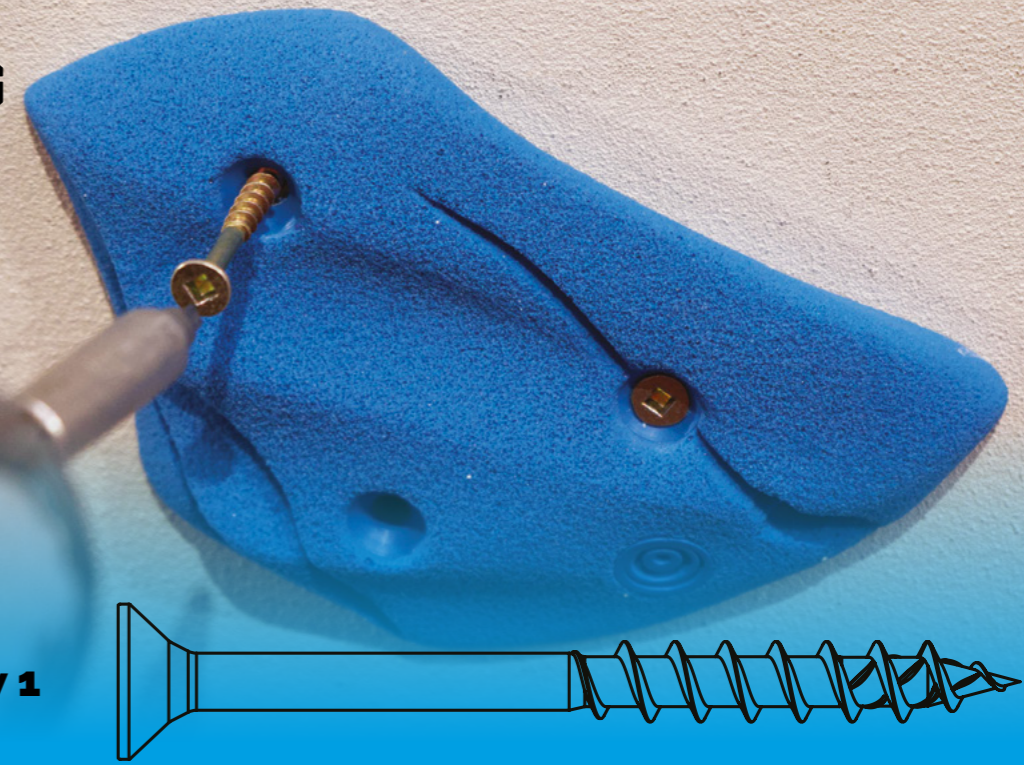

BENKY ASYM Q-Screw 1

## BENKY ASYM Q-SCREW 1

Our newly designed square drive screws are the world's first screws specifically crafted to improve the setting of climbing holds.

As we know, the daily routine of a routesetter often involves various workarounds to make tasks easier and more comfortable.

This square drive screw with an ASYM thread is not merely a new invention; it's a new design that combines the best features of different screw types to create the perfect screw for routesetting.

We are proud to collaborate with Würth, the global leader in fastening technology - passion is key!



### FEATURES

- » ASYM-powered square drive
- » The routesetter's choice
- » Durable square drive with secure fit
- » No ribs - less wear on holds and volumes
- » ASYM thread / self-drilling
- » Reduced material splitting
- » One-hand screwing
- » Material-friendly





## EWALLS BOARD LED KIT

ELEVATE YOUR CLIMBING WALL WITH INTERACTIVE ROUTESSETTING

Walltopia Board LED Kit is a comprehensive package, equipping any climbing wall with interactive route-setting and activation functionality. By harnessing the full range of features from the eWalls application, the Walltopia Board LED Kit transforms any climbing surface—whether it's a training board, boulder wall, rope wall, or speed wall—into an easily manageable canvas for routesetters and climbing gym managers. It provides tools to create, store, and share routes, create training programs and bundles for customers, and gather climber feedback.

Walltopia Board LED Kit empowers the true artists of climbing gyms—the routesetters—to showcase, sell, and stream their routes through the eWalls Marketplace. It brings the concept of Walltopia Lambda-CDM Climbing Walls to any custom-built climbing wall.

Compare eWalls Board LED Kit and eWalls Board LED Kit Lite with others:

**ewalls**  
Board LED Kit

others

customized board	✓	✗
LEDs	1200	900
LEDs per hold	customizable	fixed
holds selection	your choice	fixed
active routes	unlimited	1
create bundles/trainings	✓	✗
monetization	✓	✗
spares	200	0
LED equalizer when IDLE	✓	✗
route sharing	✓	✗
expansion option	✓	✗
price EXW	\$1780	\$2500+

[walltopia.com/products/ewalls-board-led-kit](http://walltopia.com/products/ewalls-board-led-kit)

**ewalls**  
Board LED Kit Lite

others

customized board	✓	✗
LEDs	300	200
holds selection	your choice	fixed
active routes	1	1
create bundles/trainings	✓	✗
monetization	✓	✗
spares	100	66
route sharing	✓	✗
price EXW	\$795	\$880+

[sales@walltopia.com](mailto:sales@walltopia.com)

## QUANTUM TRAINING BOARD

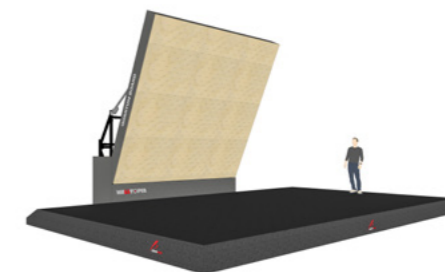

**IMPRESSIVE SIZE FOR MAXIMUM MOVEMENT**

Measuring at 4.5 x 4.5 meters, the Quantum Board is the largest training board on the market. This generous size offers more room for dynamic movements, accommodating advanced climbing techniques and diverse training routines.

**INNOVATIVE SKUISH MATERIAL FOR FINGER-FRIENDLY HOLDS**

Many of the holds are made from Skuish, a unique material developed by Composite X, in addition to traditional PE and PU options. Skuish provides a softer, more flexible texture, reducing strain on climbers' fingers and enhancing comfort during long or intense training sessions.

**ERGONOMICALLY DESIGNED HOLDS**

The Quantum Board comes with the HRT "500" climbing holds set, specifically designed with ergonomics in mind. These holds offer a comfortable grip, making them suitable for climbers of all skill levels and for extended training sessions without discomfort.

**BOULDER WALL HEIGHT & FLOORING**

The Quantum Board's 4.5 m height matches standard boulder walls. We recommend the Climbat BM300 for training boards, offering 300 mm thickness, multilayer design, optimal stiffness, excellent energy absorption, and a supportive surface for climbers during intense training sessions.

**CLIMBABLE SIDE AND TOP PANELS**

The Quantum Board includes integrated side and top panels that are also climbable, significantly expanding the training area. These panels provide unique climbing routes, adding variety and allowing for more complex movements in every session.

**EFFICIENT MULTI-USER TRAINING**

The large surface area allows multiple routes to be active simultaneously, which is ideal for busy gyms or group training sessions. Climbers can easily rotate and swap routes without downtime, enhancing the training experience for everyone.

[walltopia.com/products/quantum-board](http://walltopia.com/products/quantum-board)

[sales@walltopia.com](mailto:sales@walltopia.com)



## LAMBDA-CDM CLIMBING WALL

**THE ROUTESETTER'S PATH TO BEING A ROCK STAR —**  
A UNIVERSAL PLATFORM FOR CLIMBING ROUTE MANAGEMENT, SHARING, AND MONETIZATION.

The mission of Lambda-CDM Climbing Walls is to establish a platform that fosters an interconnected global climbing community, resolving the limitations of location-based routesetting. By creating a platform where every climbing gym can access the best routes, the Lambda-CDM Climbing Walls aims to make climbing experiences accessible to all. Its mission is to create a marketplace for routesetting, enabling routesetters to monetize their portfolios and gain global

recognition. This initiative aspires to make routesetters internationally renowned, creating a win-win-win scenario for gym owners, routesetters, and climbers.

Lambda-CDM Climbing Walls is structured on the basis of: A set of climbing wall modules, eWalls – a routesetting, route-activating, and sharing application, a routes marketplace, and a database of applicable climbing hold sets.

### A SET OF CLIMBING WALL MODULES

Pre-designed and engineered Lambda-CDM Climbing Wall modules, including boulder walls, rope walls, and training boards, created by the Walltopia design team by the latest climbing wall design trends.

### A DATABASE OF APPLICABLE CLIMBING HOLD SETS

A comprehensive database of applicable climbing hold sets from any brand or producer.

### EWALLS – ROUTESETTING AND ROUTE-ACTIVATING AND SHARING APP

eWalls app for routesetters, climbers, and gym owners, allowing the creation and loading of routes in any climbing gym equipped with Lambda-CDM Climbing Wall Modules.

### EWALLS ROUTES MARKETPLACE

A feature of the eWalls app is a repository of climbing routes, which are copyrighted content owned by routesetters or created collaboratively with gyms. The business model is based on selling or temporary usage, much like the streaming of digital content products.

## BENEFITS OF LAMBDA-CDM CLIMBING WALLS FOR ROUTESETTERS

Lambda-CDM Climbing Walls allows routesetters to develop an online portfolio, showcasing their skills and creativity to a global audience. This platform enables routesetters to monetize their work, creating a longtail selling effect where their routes continue to generate income over time. By reaching a wider market and receiving feedback from climbers worldwide, routesetters can enhance their reputation and grow their professional opportunities.



### MONETIZATION

Listing routes in the marketplace allows revenue generation from purchases and streams, turning routesetting expertise into a long-term income source.



### GLOBAL REACH AND INDUSTRY RECOGNITION

Creating and sharing routes online allows access to climbing gyms globally, expanding reach and building industry recognition.



### FEEDBACK

Reception of valuable feedback about routesets directly from climbers enhances routesetting quality.

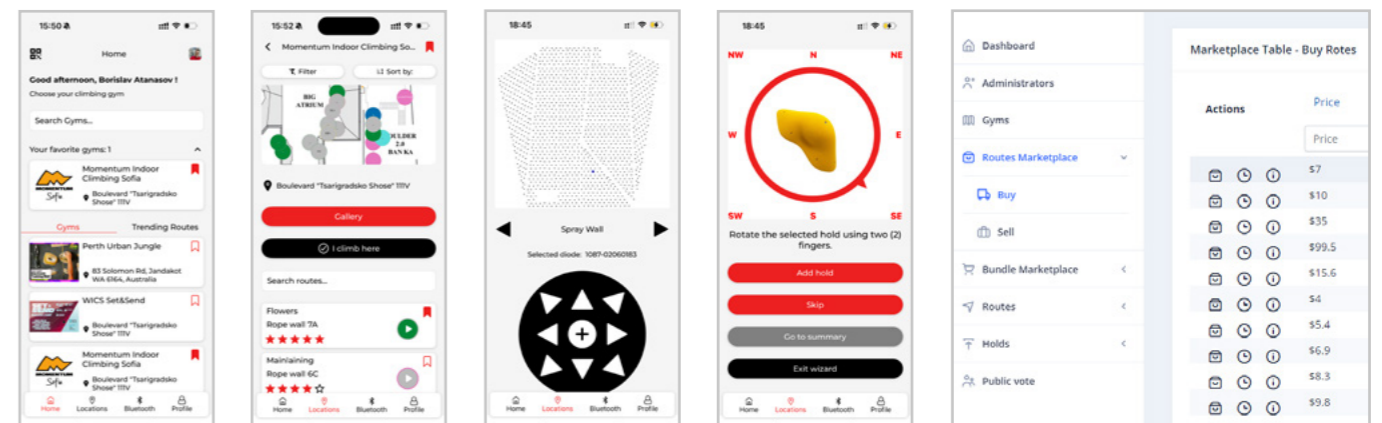



## EXTRA PROTECTION: HOW SMART ADD-ONS MAKE AUTOBELAY ZONES SAFER

### SELF BELAY

Self Belay is a patent-awarded climbing connector that increases safety and reduces the needs for operational staff in climbing centers. The safest and best selling climbing connector on the market with over 18,000 units sold has now upgraded to be even safer offering double redundancy.

- » **Secure climbing access:** Ensures users can only ascend when securely connected to the device, and disconnection is only possible once safely on the ground.
- » **Unmatched safety features:** The Gate system adds an extra layer of security - prevents unauthorized disconnections, even if a key is damaged.
- » **Efficient supervision:** Optimize staff-to-climber ratios, allowing just 2 instructors to supervise groups of up to 20 climbers.
- » **Child-friendly design:** Easy for children as young as 3+ to use, promoting both safety and independence.
- » **Durability that lasts:** Built for longevity with reinforced covers, stronger rivets, bolts, and clips.
- » **Certified excellence:** Meets the highest safety standards, certified under EN 362:2004T.

### SMART GATE

SmartGate ensures climbing gym users are securely connected to autobelay devices addressing the growing concern of human error with autobelay devices. It helps gym operators maintain high safety standards and operate with a peace of mind.

SmartGate uses a vinyl gate with orientation detection to ensure climbers are attached to the autobelay system. If a climber forgets to attach, an alarm sounds, and visual signals alert staff, allowing immediate intervention. SmartGate is user-friendly, requiring no additional sensors or equipment for climbers, and is designed for easy installation. The system is “plug-and-play,” with the gate powered by standard power outlets behind the wall, and it can be easily retrofitted to any existing climbing wall.

- » Audible and visual alarm for unclipped climbers
- » Fully automated system
- » No prerequisites for climbers to be detected
- » Easy implementation, retrofit to existing climbing walls
- » Custom design of vinyl gates with system integration
- » Automated system self-checks and operator alerts

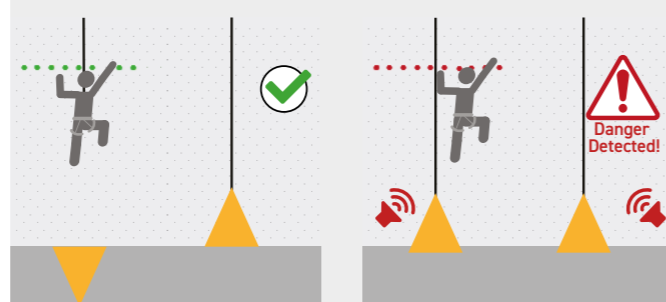

Self Belay and Smart Gate are available to order at



## WOULD YOU BUY A CAR WITHOUT AN AIRBAG?

THEN WHY CONSIDER A ROPE CLIMBING WALL WITHOUT PROPER SAFETY FLOORING?

ONE MORE LIFE SIGNIFICANTLY DECREASES THE RISK OF SEVERE INJURY OR DEATH FROM A FALL FROM UP TO 17 M!

Falling from 17 meters is like crashing a car at 66 km/h. The human body accelerates to the same speed and the impact forces are the equivalent. In case of such an accident, it's not the fall but the sudden stop that causes harm — what scientists call “severe deceleration.” The automotive industry uses inflatable airbags to reduce the deceleration and absorb kinetic energy applied to the human body. In climbing gyms, the last line of defense that can serve the same purpose in case of human error or gear failure, is the safety flooring.

To validate the effectiveness of our One More Life (OML) flooring in mitigating fall impacts, we utilize testing protocols based on the standards from the US and EU Highway Traffic Administrations. These standards, designed to measure chest and head impact during high-speed collisions, provide a framework for assessing safety in climbing environments.

Our testing involves a human analog, specifically a 70 kg crash test dummy equipped with head and chest accelerometers, traditionally used in the automotive industry. By replicating falls from 17 meters (the top of a climbing wall), we collect and analyze precise data, comparing it to the automotive safety benchmarks.

Although no formal safety standards exist within the climbing industry, we feel responsible for providing the highest level of protection for climbers as product manufacturers.

### What about proper training? Isn't that enough?

Even with proper training, climbing happens above the ground, gravity works and accidents happen. Studies show 90-95% of auto belay incidents are caused by human error, such as forgetting to clip in or skipping safety checks. Both beginners and experienced climbers make these mistakes. Beginners may not yet grasp the system, while experienced climbers although proficient in their gear operations, may still fall victim to complacency or distractions—common causes of accidents even among seasoned athletes. And for children, who bring boundless energy but often lack the focus or technical precision needed for safe climbing, the added layer of protection is indispensable.

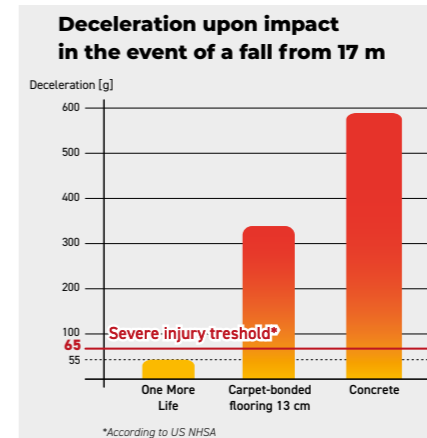

### What about the cost?

OML is 15-20% more expensive than thinner mats designed for falls up to the first clip. In fact, OML costs as much as premium boulder mats but its life saving capability is priceless.

### Falls after the first clip are rare, though, right?

Rare, yes, but can anyone promise they'll never happen? Gravity is beyond our control—it keeps us climbing, but it's also what brings us down to the ground.

### Just like with cars:

- How often do you drive?
- How often do you crash?
- Would you drive a car without airbags?



## WORLD'S FIRST DRAINABLE OUTDOOR MAT ECODRAIN®

- » specially designed for outdoor use
- » 100% water-permeable
- » 100% recyclable
- » multi-layer core made of synthetic fiber
- » cover made of drainable fabric structure
- » flame-retardant according to B1
- » with slatted frame



## BOULDER MAT SYSTEM EXKLUSIV TYPE 2

- » combination core with step distribution surface
- » top 30 mm composite foam RG 100
- » bottom 270 mm core PU RG 23
- » firmly glued and high-frequency welded
- » edge reinforced
- » tarpaulin or carpet over the entire surface or carpet in partial areas

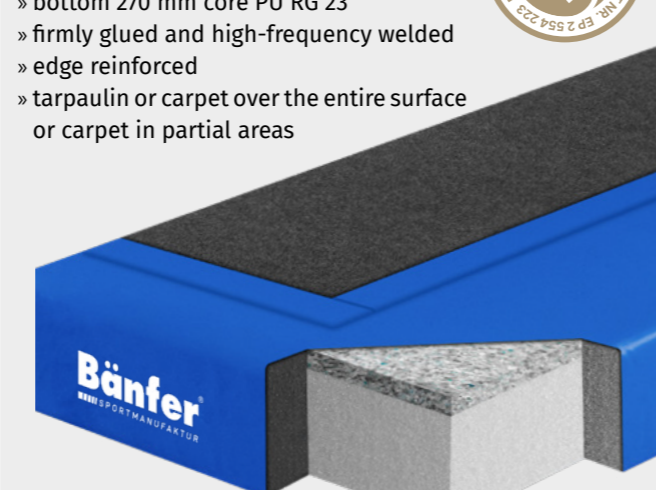

# BÄNFER EQUIPMENT 2025

## BOULDER AND URBANSPORT PRODUCTS MADE IN GERMANY

### THE WORLD'S FIRST REAL AND 100% DRAINABLE OUTDOOR MAT-SYSTEM

EcoDrain is the world's first and unique outdoor fall protection mat system. Because sustainability is more important today than ever, our Eco-Drain outdoor fall protection mats consist of filaments and a grid top layer that are recyclable and offer not only environmentally friendly fall protection, but also a long-lasting solution for outdoor use.

Thanks to this new technology, our EcoDrain fall protection mats are 100% water-permeable, extremely weather-resistant and also easy to clean with water jets, but at the same time offer our tried and tested and optimal protection against falls and are flame-retardant according to B1. And the best thing - the substructure is also completely recyclable.



ECODRAIN at Universität Bern

ECODRAIN at Universität Bern

### BOULDER MATS CUSTOM MADE TO MEASURE

Bänfer bouldering mats are custom made to measure with different core variants and thicknesses and are covered with particularly hard-wearing materials such as tarpaulin, carpet or permeable grid structures, which are velcroed onto the top and visible sides of the core. But the special feature lies in the core. Our combination core consists of a solid pressure distribution plate, which is firmly glued to a softer base layer made of PU foam and has a unique S-connection system to enable seamless mat surfaces, the greatest possible safety and stability. The firm interlocking of the mat cores means that wedging due to the athlete's use is almost impossible. All entry and special wall areas are reinforced with a solid foam. All seams are also high-frequency welded on a tarpaulin surface of up to 100 sqm for a longer lifespan, because wearprone components such as zippers and joint tabs are eliminated. The patented system is individually installed on site by our fitters and adapted to the walls.



EXCLUSIVE TYPE 2 mat at E4 Nürnberg

## CUSTOM IMPACT PROTECTION FOR RAILINGS IMPACTSAFE

- » variation of foams available
- » durable and stable
- » cover made of tarpaulin or carpet mat
- » expandable
- » available in different colors



### INDIVIDUAL CUSTOM MADE IMPACT PROTECTION

Custom-made protective pads with a foam core and a top made of tarpaulin material for hazardous areas such as door frames, wall corners and steel beams, handrails, staircases and much more. Optionally available with Velcro strips and also suitable for outdoor use thanks to high-frequency welding. Perfect for bike parks, ski slopes, railings and more!

We have no standard in terms of dimensions, format, cut and materials. We produce individually according to your wishes to your utmost satisfaction, e.g. padded stairs, seating areas, ramps, shoe box pads and much more.



RAIL PROTECTION at Edelweiß Südstadt, Wien

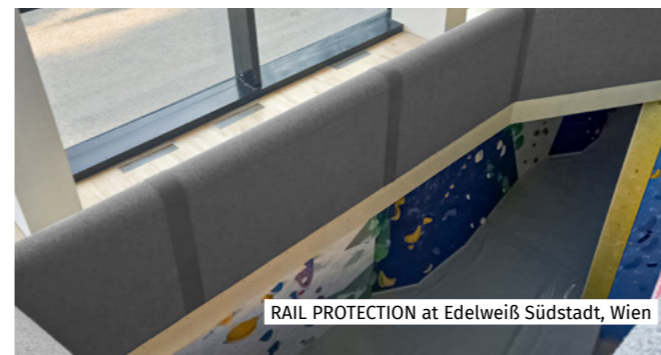

RAIL PROTECTION at Edelweiß Südstadt, Wien

## CLIMBING SAFETY AUTO-BELAY MAT

- » 10 mm monocore made of light-weight PE foam
- » cover made of tarpaulin material
- » durable and stable
- » handles
- » information signs



### AUTO-BELAY SAFETY MAT

Brand new in our product range is the Auto-Belay mat. A safety device and at the same time an information sign for climbing gyms. In cooperation with our partner the DAV (Deutscher Alpenverein) we have developed and produced these robust entry barriers. The Auto-Belay Safety mats are intentionally large and trapezoidal with a height of 1.5 m and a width of 1.4 m on the ground. This Auto-Belay mats are designed to cover as many of the route entry areas as possible in order to prevent people from climbing past the route.

## URBAN PARCOUR AND NINJA MODULES URBANBLOX

- » PU-foam core with PE-coating
- » durable and stable
- » cover made of tarpaulin PVC material
- » reinforced corners
- » unique velcro system
- » expandable
- » available in different colors



### URBANBLOX PARCOUR AND NINJA SYSTEM

We offering a range of high-quality modules specifically for Urbansports, for a safe environment paired with almost endless possible combinations. Each UrbanBlox module can be used as a stand alone module or can be combined with the wide product range and connected together with our Velcomp system.

Need further informations about our products or need help with a sports project? Our sales team Andrea Rothe and André Friderrizi are keen to help you and answer your questions: [bouldern@baenfer.de](mailto:bouldern@baenfer.de) or phone +49-5621-7878-36

[www.baenfer.de](http://www.baenfer.de)



## BLOCZ: A STUNNING VARIETY OF NEW PRODUCTS



Blocz unites gym owners, manufacturers of bouldering products and passionate climbers under one roof. This unique synergy enables us to comprehend the diverse needs and desires of our customers from multiple angles. By actively seeking input from bouldering gyms, we continually innovate, crafting fresh, standout designs, and relentlessly enhancing the quality and durability of our products.

### TAKE CARE-REPAIR! OUR DIY UPCYCLING KIT

Affordable and eco-friendly: Our upcycling kit offers a budget-friendly, sustainable solution. Refresh your climbing gear in over 60 color options—same colour or something new, the choice is yours!



### THE BLOCZ SERVICE VARIETY

#### WALLS

Together, we collaborate on crafting your distinctive wall design and execute on-site construction.

#### MATS

We provide boulder mats with a choice of carpet or PVC tops.

#### KILTER BOARD FRAME

Something special from Blocz production: We build customizable Kilter Board frames from wood. Whether it's for a Homewall or an Original Layout—we offer the proper size for you.

### OUR MACRO VOLUMES—100 % RECYCLED PLASTIC

At Blocz, we proudly achieved a groundbreaking milestone by introducing the world's first macro volume crafted entirely from 100% recycled industrial waste. Beyond its visible exterior, every component embodies a sustainable transformation of industrial waste, granting it a second life. Sustainability is at the core of our values, and this is just one of the many steps we are taking to contribute to a greener future.



### BLOCZ AS PRODUCER

Blocz takes pride in being the manufacturer of holds, wooden volumes, and macro volumes for esteemed brands like Blue-pill, Unit Holds, Chapter Climbing, Community Climbing Equipment, Rustam Climbing and our very own Blocz products.

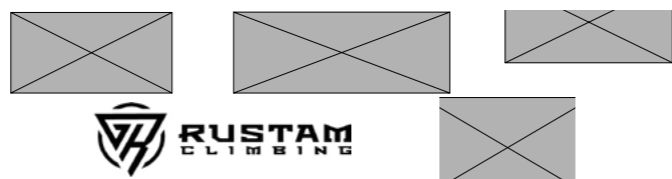

[www.blocz.de](http://www.blocz.de)

## FIRST LOOK AT BLOCZ'S NEW PRODUCTS

### ESPERANTO – NEW MACROS AND HOLDS

The new Esperanto line pays homage to the language of the same name, which was created as an attempt to connect people across national language barriers. As diverse as the people who speak Esperanto are the geometric elements that come together here. The range combines sharp, angular edges with gently curved, rounded shapes. These contrasting designs merge into unique objects—the base structure is triangular, while the 'top' is soft and round.



Esperanto's aim is to combine different shapes into a harmonious whole. The set, consisting of 17 macros and 70 PU holds, is harmonious both as a complete set and as individual pieces.

### FONTAINEBLOCZ UPGRADE – NOW PE HOLDS

The Fontaineblocz line is getting stronger. With the addition of the classic beginner's holds, pinches and jugs, we are making the French indoor nature experience accessible to even more experienced levels. Combined with an optimized, more robust surface made of PE, the set now offers not only more grip but also a longer service life.

### REDESIGNED SQUARE VOLUMES

We have redesigned our popular Squares—and the result sets new standards! The classic design retains its proven functionality while offering even more flexibility. Thanks to a new edge and dynamic asymmetry, you can always mount the perfect angle on the wall.

The set consists of 27 new volumes, ranging from small pieces to volumes with an impressive edge length of 2.20 meters.

### UNIT HOLDS X BLOCZ – NEW BLADE RUNNER VOLUMES

The Blade Runner volumes are an absolute novelty in the Blocz product portfolio, as the wooden volumes are the result of a first-time collaboration with Unit Holds. The futuristic design of the Blade Runner not only impresses visually with its sharp lines and minimalist design, but also allows a particularly technical and multi-faceted route setting.

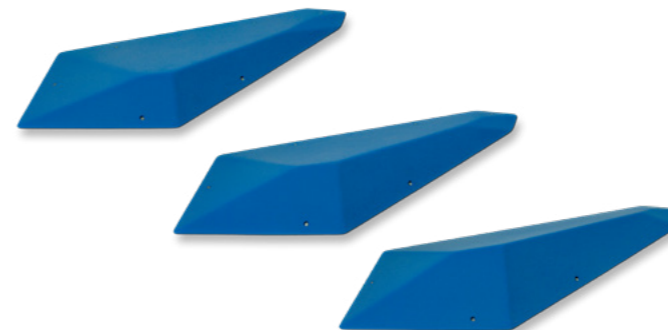



blue pill

holds · volumes · equipment

### DOPE

The Dopes are an impressive macro line with four different shapes and four subtypes: Jugs, Pockets, Edges and Slopers. Each subtype represents a distinct shape that can be used individually to create various climbing routes. The Dopes are an ideal addition to the existing bluepill PU lines.

[www.bluepill-climbing.com](http://www.bluepill-climbing.com)

### MONZOS

The Monzos line, inspired by the rock type Monzogranite, stands out with its texture, akin to those found in nature. Soft shapes meet hard structures, turning dreams of artificial climbing walls into reality! With 152 holds and footholds made of PE in all sizes, these holds leave nothing to be desired: pockets, jugs, slopers and crimps bring the natural climbing experience to the climbing gym!

Explore our newly redesigned website and discover everything we have to offer!  
[www.community-climbing.com](http://www.community-climbing.com)



Community Climbing Equipment

## BLUEPILL IT'S YOUR CHOICE

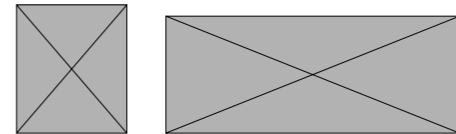

When details matter, bluepill delivers. Fusing modern aesthetics with functionality, bluepill effortlessly balances essential elements with stylish accents. We offer bold competition lines featuring creative macro shapes, durable holds for everyday use, and a range of wooden volumes designed to transform your wall dynamics. Our products redefine the art of route setting, whether in commercial gyms or high-level competitions.

### IMPOSSIBLE LINE – OUR HIGHLIGHT IN VERSATILITY

The Impossible Line is a significant extension of the well-known Competition Line and impresses with its versatility. With 9 special macros and more than 220 holds, it offers a wide range of special shapes—from universal spaxes to large, compelling holds. This line can also easily be combined with the Dope Macros and the Fiber Impression Line, which opens up numerous application possibilities.

### PILLS - NEW LINE

The name speaks for itself: bluepill launches the new Pills product line this year. The focus is on the two-piece macro set and 144 PE holds. The set impresses with its simple, functional design and is particularly suitable for commercial use. From small, sharp holds to large, imposing macros, this impressive new set not only offers good holds but also introduces challenging slopers, making every climb more engaging and exciting!



## COMMUNITY CLIMBING EQUIPMENT (CCE) – EVERYTHING FOR CLIMBING GYMS AND ROUTE SETTERS

We are not just in the climbing business—we are part of a thriving community! That's why climbers, boulderers, route setters, shapers, trainers, and more come together to create something special. We are all about designing and developing the best products for you. It is gear made by the community, for the community.

Our mission? To deliver the ultimate all-in-one package for route setters, gym owners, and managers. We streamline your processes, provide top-notch equipment, and free up your time so you can focus on what really matters: setting epic routes and climbing to new heights!

### CCE COMMUNITY PLATES A GAME CHANGER IN ROUTE SETTING

And besides, introducing our Community Plates — versatile panels designed for quick installation on flat surfaces like volumes or walls. These game-changing plates transform any textured area into a clean slate, allowing you to refresh your boulder problems and routes effortlessly. The set includes seven geometric shapes, inspired by the ancient Chinese puzzle game 'Tangram', enabling endless combinations for creative route setting.

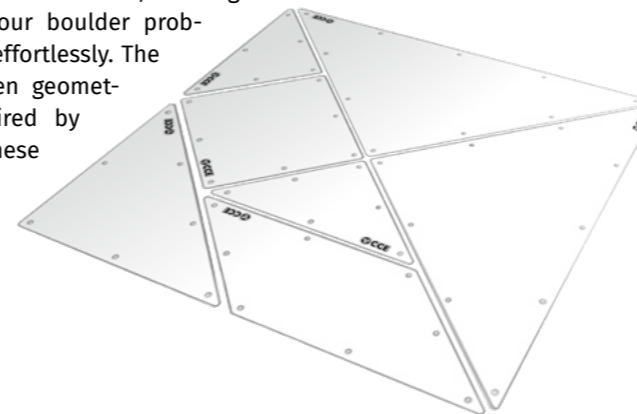

### SLYCERS – LATEST COLLECTION OF MACROS & HOLDS

The new hold and macro series from CCE stands out with its simplicity! Featuring 110 PE holds and 9 macros made from recycled plastic, the edges, curves, and sizes seamlessly blend together. On one side, you will find generously grippable jugs in an array of sizes, while the other side boasts challenging edges and crimps that will put your skills to the test. This clever design allows you to create everything from straightforward routes to intricate challenges.





**kletterkultur**



**re:white**

## KLETTERKULTUR (CLIMBING CULTURE) – EXPERT SERVICE FOR BOULDERING & CLIMBING GYMS

We draw on years of experience in route setting, climbing gym design, product sales, and knowledge sharing through hands-on workshops, ensuring you receive top-tier service. Our annual in-house event, Hold Together, held each spring, offered engaging presentations and invaluable networking opportunities that many of you enjoyed and appreciated.

### OUR SERVICES

In collaboration with Blocz, we bring your vision for your climbing gym to life. We are proud to be the exclusive distributor of climbing holds, macros and volumes from several renowned brands exclusively in Germany, Austria, Switzerland but also worldwide. Our expertise extends far beyond just holds—we offer comprehensive services, from conceptualizing your gym layout (including storage, cleaning, and related facilities) to providing specialized advice on the best product selection for your needs, no matter whether you are equipping a new space or expanding an existing one.

We offer tailored consulting services beyond just holds, volumes, and macros. Our expertise covers everything from signage and cleaning systems up to screws and bits. Whether you are setting up your gym for the first time, expanding, or refreshing your equipment, we help you to create the ideal product selection based on proven insights and your individual budget! Our team also supports you with route setting, from initial installations to developing comprehensive strategies. You can easily check the availability of all in-stock products in our webshop online and place custom orders in your preferred colours. We also provide expert advice on product advertising and offer route setting training to ensure your success. Don't hesitate to contact us!

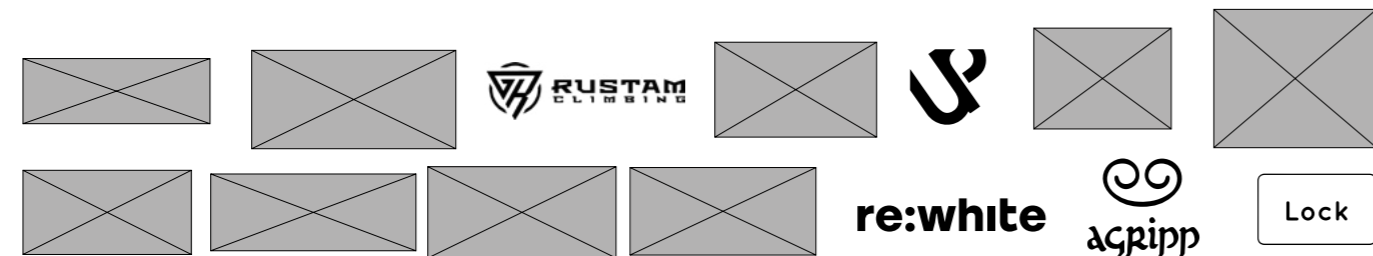

## RE:WHITE IS MAKING A COMEBACK

We are excited to announce that re:white—a brand known for high quality, personalized products, has officially joined the Kletterkultur. With this partnership, we are proud to offer climbers a reliable and premium chalk that meets the highest standards of performance and environmental responsibility. Whether you are scaling indoor walls or conquering outdoor rock, re:white ensures that you have the best in your hands.

We have got the perfect product for every preference: whether fine, crushed, liquid, or brand new—flakes. Our flakes are the latest innovation, seawater based, making them especially sustainable and eco-friendly.

### LET'S CHALK ABOUT CLIMBING – OUR SERVICES

As a business, you can conveniently order chalk from the Kletterkultur webshop at any time. With a well-stocked inventory, we ensure fast and reliable delivery, so your order gets to you in no time! Also for individual customers, you can easily order your favourites directly online.

Looking to provide your customers with top-quality chalk and personalize it too? Whether you are a climbing gym or an online shop, we will brand your favorite products exactly how you envision them!

SHOP ONLINE:





**Beal**

HIGHLY FRIENDLY

## AT BEAL, WE BELIEVE IN FRIENDSHIP.

Since 1976, BEAL has been a global leader in climbing and safety ropes, designing and manufacturing equipment and services for vertical exploration. Guided by values of freedom and enjoyment, we develop "rope-friendly" solutions for athletes and professionals in the vertical world.

Our innovative and bold product ranges meet the needs of every user, whether beginner or expert. Friendship, which lies at the heart of our story and yours, embodies the collaboration and trust essential to the sports and professions we equip. At BEAL, friendship is in our DNA and inspires every creation.

### WALL SCHOOL 10.2MM UNICORE

The reference for indoor ropes worldwide. The perfect compromise between durability and smooth handling. Strong and equipped with a thick, smooth sheath, it perfectly resists abrasion.

### The UNICORE process is onboard

Another advantage of this rope is the UNICORE technology. This process bonds the core and sheath of the rope during manufacturing to prevent sheath slippage and provide increased durability.



### Key Features

- » Excellent handling
- » Kid-friendly
- » Intermediate diameter
- » Abrasion resistance
- » UNICORE technology
- » 100% recyclable

### Specifications

**Material:** 100% Polyamide  
**Diameter:** 10.2 mm  
**Laboratory fall rating:** 7  
**Single impact force:** 8.2 kN  
**Weight per meter:** 64 g

Photo: Nurisso Samuel



## THE BIRDIE IS BACK!

[www.beal-planet.com](http://www.beal-planet.com)

### BIRDIE

Giving slack has never been so easy! BEAL's iconic assisted-braking belay device returns with an even more elegant and robust design!

- » **Rope Friendly:** Softness and technicality that respect the rope.
- » **Climber Friendly:** Visible and adapted handling zone.
- » **Planet Friendly:** 100% metallic.

### Key Features

- » **Ease of belaying:** Smoothness for giving slack.
- » **Soft and comfortable:** The rope glides without twisting.
- » **Less effort for the belayer** during route work and repeated falls.
- » **Compatible** with single ropes from 8.5mm to 10.5mm.

### Specifications

**Materials:** Aluminum / Steel / Stainless Steel  
**Weight:** 210 g  
**Size:** One size

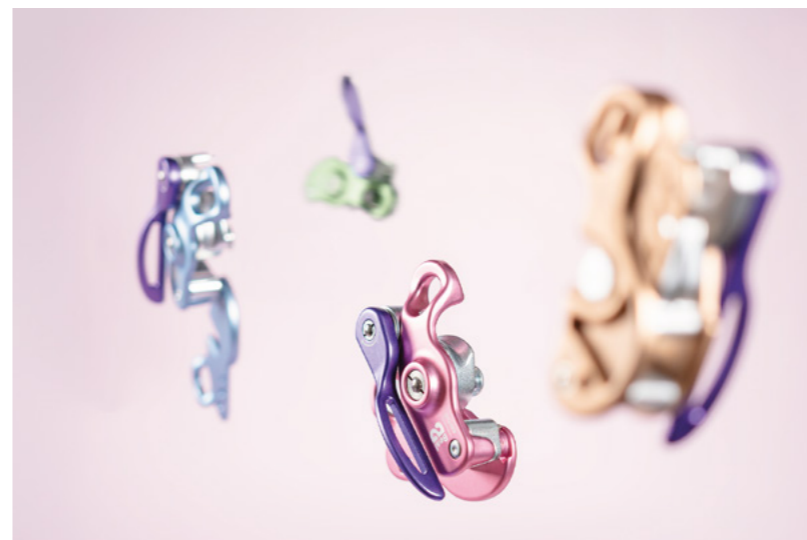



World Cup Boulder CZ 2023 - Photo by Petr Chodura



# 9c PROFESSIONAL

## THE ONE-STOP SHOP FOR CLIMBING PROFESSIONALS!

9cprofessional.com



At 9c Professional, we offer a carefully curated selection of high-quality gear for routesetters, climbing gyms, and boulder gyms.

We provide a hand-picked collection of quality routesetting gear and gym equipment, selected by two passionate routesetters and seasoned climbers to meet all your demands.

Get expert advice, quality gear, and everything you need to elevate your experience, all in one place.



### ROUTESETTER BAG, TOOL BAG

The ultimate toolbelt to make your routesetting work easier, more efficient, allowing you to elevate your creativity. Available in two sizes (large/small) and two belt sizes (men/women).

### T-HANDLE HEX WRENCH (8MM)

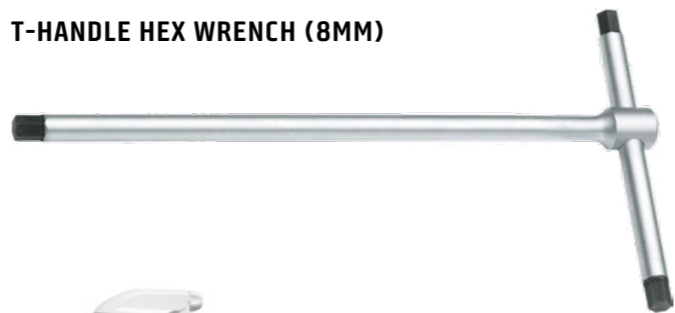

### CLEANING! SHOES (1L), SHOE REFRESH SPRAY

Eliminate those stinky microorganisms! This very effective spray prevents people from finding your rental shoes by smell alone :) Apply directly to the shoes and let dry before use.



### IMPACT DRIVER BITS AND THREAD CUTTERS

Thread cutting bits for refurbishing damaged M10 T-nuts, short or extra-long 8mm hex bits for M10 bolts, or 'normal' Torx bits. We have a full selection in stock for you!

### RENTAL SHOES!



### JUST 4 RENT, RENTAL CLIMBING SHOES

Exceptionally durable(!) rental climbing shoes that still allow for excellent friction. Designed for new climbers, they ensure an enjoyable experience, and turn new customers into returning climbers.



### O-FLEX 10.2MM ROPE, INDOOR GYM ROPE

Supple yet durable, this rope is developed specifically for indoor climbing gyms. After trying numerous brands, we've finally found a gym rope we are happy to recommend. Available in rolls of 200m.

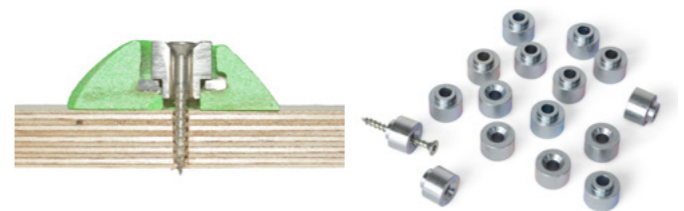

### RINGO, SCREW INSERTS

Convert bolt-on holds to screw-on holds with these stainless-steel adaptors. Perfect for creative routesetters seeking precise placement, they allow for adding holds to volumes or near wall edges.



### INDOORPRO, GYM BRUSH STICK

The Stick Brush developed for gyms. This big stick won't break, ensuring long-lasting use. The adjustable brush head rotates 180° and can mount two brushes for versatile cleaning.



### MAGNETTO, MAGNETIC BIT AND SCREW HOLDER

The Magnetic Bit Holder for your impact driver! This easy-to-install accessory simplifies your routesetting experience: no more searching for bits or screws in your bag. Compatible with Makita and DeWalt.



### PRO GAFF FLUO (24MM), ROUTESSETTING TAPE

Premium routesetting tape. This strong paper tape is easy to roll, tear, and label with any pen, while offering excellent edge stability. It can be removed residue-free from most surfaces for reuse.



To book your **free consultation**, simply scan the QR code below and quote **VLP24**



Jez is a seasoned professional with extensive experience in the climbing and extreme sports industry, blending practical and academic expertise. With a background in sports management and military training, he has managed operational and strategic projects for climbing facilities worldwide.



Don't forget to check out Jez Tapping on LinkedIn to stay connected with the latest news and insights that can help your business grow!



## SCALING UP: WHY PROFESSIONAL CONSULTANTS ARE ESSENTIAL FOR CLIMBING GYM GROWTH

BY JEZ TAPPING

The evolving indoor climbing gym industry is increasingly relying on commercial consultants to enhance business operations and growth. Key services are in demand and consultants are helping gyms transition into competitive, well-rounded commercial enterprises that can hold their own in the broader health and fitness market. One of the most powerful tools a consultant can offer is an independent perspective. **Here is one insight from a consultant on how to refine your Customer Journeys and what to consider.**

When it comes to **casual users** designing a robust customer journey for indoor climbing walls involves balancing customer satisfaction, safety, and operational efficiency to drive growth and minimise liabilities. It starts with strong pre-visit marketing and seamless online booking systems – ensuring the look and feel of the service is consistent and doesn't create anxiety in users through mixed messaging.

Efficient on-site check-ins with clear safety protocols help users relax, as many first-time climbers are dealing with a perceived "risky" environment and an unfamiliar social setting – often a point overlooked by passion operators. All too common the customer journey up until now will have been dominated by a marketeer and a technical advisor, who focus on stimulating and controlling customers respectfully. Post-climb feedback mechanisms, regular mystery shopping, and staff training are all crucial to ongoing improvement. It's essential to listen to both active and inactive users to ensure continuous engagement.

Climbing gyms often fall into the trap of the "internal echo-chamber" and "survivor bias". The most frequent visitors, or "hardcore" climbers, are often the loudest group, steering decisions that may not align with broader business interests. These individuals typically account for less than 5% of the total income of a centre. By contrast, long term loyalty and customer retention significantly improve when regular, positive interactions with users is ingrained in the centre's workforce.

Probability of visiting next month if spoken to THIS month (Paul Bedford, Retention Guru)

1 interaction	2-3 interactions	+4 interactions
20%	50%	80%

Simple touchpoints and basic staff training can have a dramatic effect on the long term viability of your business. These interactions need to be nothing more than "Hello", "Goodbye", "How was your session today", however magical things start to occur when you ask really insightful questions, turning casual visits into emotionally memorable experiences, and thus forging strong bonds with your brand.

The key takeaway from this is building brand loyalty and positive brand association. The best way to achieve this is by treating every customer as an individual - a core principle that also lends itself well to the positive EDIB (Equality, Diversity, Inclusivity, and a sense of Belonging) attributes that climbing has at its roots. With core systems in place, empowered staff, and a safe environment for all, there's no reason why your customer base shouldn't grow significantly.

Your next biggest income stream is the **coached user. If your coaching program isn't matching your casual income, then you are missing out.** To continue reading and explore other common operator pain points, scan the QR code.



## EXPERTS JEZ TAPPING AND ARRAMPICA WORKING TOGETHER TO TRANSFORM YOUR CLIMBING GYM INTO A PROFIT-DRIVEN, EFFICIENT BUSINESS.

### ARRAMPICA – INDUSTRY LEADING EXPERTISE AT AN AFFORDABLE PRICE

Since 2001, Arrampica Limited has been a trusted technical advisor and partner for climbing gym operators, offering comprehensive services that help ensure your staff are equipped with the right skills and qualifications. Our goal is to provide your team with the confidence they need to perform their roles effectively, while keeping safety and operational excellence at the forefront.

#### Staff training & development made easy

Our approach focuses on mitigating risks by integrating advanced control measures with ongoing staff development and training programs tailored to your facility's unique needs. Arrampica's signature system is designed to streamline staff management and qualification processes, allowing you to monitor and enhance your team's competencies with ease; reducing cost and minimising staff time on admin.

#### How it works: the Arrampica Portal

Whether you operate a single climbing gym, high ropes courses, complex adventure parks, or multiple locations; the Arrampica Portal is your go-to resource for tracking staff qualifications, ensuring safety compliance, and planning future growth. With our portal, you and your team will benefit from:

- » **Pre-course online learning** to prepare staff before training begins.
- » **Access to a diverse selection of courses** specifically tailored to your operational requirements.
- » **An innovative badge system** that ensures you're always up to date on staff certifications and renewal needs.
- » **A custom-built platform** that evolves with your business—ideal for expanding into new activities, adding more sites, or navigating staff role changes.
- » **Stress-free operations** with a streamlined system that saves you time and delivers great value.
- » **Scalable solution** that whether you are one gym or ten will grow to meet the needs and complexity of your organisation.
- » **Seamless integration** with central control measures, ensuring operators and trainers have the latest updates for easy compliance and smooth operations.

#### Take the next step

As your climbing operations continues to grow or just to streamline your current offering, let Arrampica help you create a safer, more efficient, and professional environment with ease. Scan the link below to explore how our system can become a game-changer for your operations.





## ATARI CLIMBING

[www.atariclimbing.com](http://www.atariclimbing.com)

Fifteen years ago, the climbing industry worldwide had a different landscape. Gyms were starting to pop up like mushrooms in cities around the globe, and climbing was slowly transitioning from a fringe sport into a mainstream activity.

Before 2010 or so, climbing gyms in many places were often still run by gym owners who managed **ALL** aspects of their facilities, including routesetting.

Around this time, we started Atari Climbing out of Belgium, where our setting careers began. Having done years of commercial setting for gyms across Europe and competition setting for multiple IFSC, Continental and European Cups we wanted to share our knowledge and passion for setting with more climbing communities. Our goal was simple: to elevate the quality and diversity of routes and boulders by offering professional routesetting services to gyms that could benefit from the expertise.

The initial years were filled with challenges. The concept of hiring external routesettters was foreign to many gym owners at the time, who were skeptical about the need to outsource something that had traditionally been handled internally. Moreover, the idea of paying a freelancer for a service that had been done in-house for free or at a minimal cost seemed unnecessary to



many owners. We often had to educate clients on the value of professional routesetting, explaining how a well-designed route could enhance climber satisfaction, reduce injury risks and boost customer retention. We began by offering consultations to demonstrate the impact of professional setting. Slowly but surely climbers started to notice differences between the routes, we often heard our routes were engaging, diverse and thoughtfully set, catering to a wider range of skill levels and climbing styles. As more climbers voiced their appreciation, gym owners began to see the benefits of investing in high-quality routesetting.

After a few years, we had the opportunity to diversify the business and we launched workshops and training programs



for new and aspiring routesettters, sharing our knowledge and expertise. In addition to the workshops, we also provide novice and advanced routesetting courses internationally (climbing gyms and national federations can contact us at [Info@atariclimbing.com](mailto:Info@atariclimbing.com) for more information or to schedule a course).

To provide new setters with all the information they were provided with in the workshops, we decided to write a comprehensive book, called "I Routesetter." The highly anticipated book—now available for ordering in the U.S.—provides a good overview of information that's important for setters everywhere to know, including basics, helpful tips and inspiration from pro setters, making it an invaluable resource for both novice and experienced setters anywhere. We hope we can help a new generation of routesettters have a sustainable, legitimate and rewarding career.



### I ROUTESETER BOOK

Atari Climbing founders Jan De Smit and Nataleigh Bell—an IFSC Official Routesetter—crafted "I Routesetter" for novice and experienced routesettters alike. The hard-cover book is packed with wisdom from their setting workshops and fueled by years of setting and consulting in climbing gyms. The "I Routesetter" book covers a wide range of important topics for commercial setting, from gear and holds to setting styles and grading.

#### Order it here:

#### For Europe you can order through:

Atari Climbing



I Routesetter



#### For U.S. customers:

Kilter Grips

(for retail purchases, select the "retail bulk order inquiry" option)



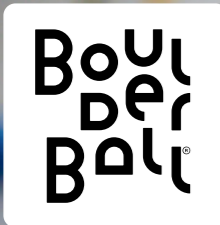

# BOULDERBALL POCKET SIZED CLIMBING

[www.boulderball.com](http://www.boulderball.com)

Climball OHG has developed and launched the globally renowned Boulderball strategy game. We're now expanding our range with the new Team Climb and are constantly working on innovative products. Our goal is to bring the thrill of climbing and its associated skills to a miniature format, so everyone can enjoy this unique experience anytime, anywhere.



**BOULDERBALL**  
The Boulderball transforms bouldering into a compact, engaging game. Climb mini-routes using just your hands and up to 3 fingers. Boost coordination, concentration, and creativity with challenging routes and special moves.



**TEAM CLIMB**  
This game includes routes and challenges for playing with the Boulderball, fostering teamwork and collaboration while having fun together.



**ONE<sup>®</sup>  
F4R  
ALL**



## SKIN CARE LOTION

[www.jacobson.com/one4all-skincare](http://www.jacobson.com/one4all-skincare)  
[www.instagram.com/one4all\\_skincare](https://www.instagram.com/one4all_skincare)

The ONE 4 ALL trademark was born of a desire to provide a friendly, cost-effective, 100% natural lotion which protects the skin, keeps it healthy, and makes it supple and resilient, which is also our mission. The lotion is hand made in Slovenia – EU. So far we are selling in Switzerland, Austria, Italy, Croatia, Sweden. Norway.



### BENEFITS

Excellent, 100 % natural lotion which protects the skin, keeps it healthy, and makes it more supple and resilient. Best used for care and management of dry, rough, tired, and cracked skin on hands, feet, heels, elbows... and everywhere else. The lotion is also great for dry and chapped lips.



*WE ARE LOOKING FOR NEW BUSINESS PARTNERS SUCH AS CLIMBING GYMS AND SHOPS WHICH WOULD BE INTERESTED TO SELL OUR PRODUCT.*

One percent of all our sales are used to help people, animals, and nature.



### IT'S REALLY SIMPLE TO USE.

It comes in a convenient bar, which is stored in an aluminum pot with a screw-on cap. You take the bar out of the pot and apply the lotion, and when you no longer need it you simply put it back in the cup and close it.

**The effects are immediate**, it quickly penetrates the skin, it smells nice, and has a pleasant feel to it.

For **climbers** who require supple and resilient skin for climbing and other activities.

- » Comes in a convenient bar in three different sizes: **35 grams, 18 grams, and 5-gram testers.**
- » Packaging is aluminum pots with screw-on caps you can take wherever you go.
- » Expiration date is three years.
- » Certified Organic in accordance with EU standards.
- » 100 % natural and biodegradable ingredients.

### ONE 4 ALL LOTION IS MADE OF

BIO extra-virgin olive oil, BIO coconut oil, BIO cold pressed jojoba oil, BIO marigold oil extract, BIO cold pressed argan oil, BIO beeswax, BIO lavender essential oil, BIO tea tree essential oil, BIO rosemary extract – antioxidant, natural vitamin E.

**Our cosmetic products are registered in the CPNP, the European portal for cosmetics.**

One 4 All is made of the most expensive oils for regeneration and skin healing.





Muskers climbing is a company focused on improving performance and prevention in climbing training, taking innovation as its axis.

Muskers' goal is to offer both novice and experienced climbers the opportunity to use innovative devices that allow them to

enjoy their sport in a coherent and sustainable way, making the most of their training, and avoiding possible injuries. All Muskers products undergo rigorous quality control as well as validation by experts before being released to the market.

## ¿WHAT IS CLIMBING GOGOR?

Gogor is a small-sized finger recovery, warming and strengthening device that fits perfectly in any pocket.

"Gogor is a device that we use on a daily basis, especially in the readaptation of pulley injuries, since it is very good for activating them and working on crimp and half-crimp grip, both concentric and eccentric," says **Andoni Ormazabal**, the renowned physiotherapist specialized in injuries derived from climbing. In 2015, the doctor in mathematics Asier Mugertza broke a pulley while rehearsing one of his projects in Etxauri. As a result of that injury, an idea that was floating around in his head began to take shape: A small, portable device that would keep his tendons and joints warm between hits and hits during the cold winter sessions, which is when the rock has the best grip, but the chances of injury are also much greater. At that time, this device was going to help him recover sooner and better from his injury. He got to work and assembled the first wooden prototype by hand, with several springs and some interchangeable strips. A little later he assembled the first metal prototype and a couple of years later he assembled several 3D printed prototypes with a more professional finish. These prototypes were distributed among climbers, coaches, physiotherapists...

and upon receiving feedback that exceeded any expectations, Asier decided to patent the idea.

He already had the product, an innovative 3-in-1 (recovery + warm-up + strengthening) small-sized portable that can be carried either in your pocket or attached to the harness. Gogor comes to fill a void not satisfied by portable fingerboards, heating pads, terrifying fitness grippers... through a system that is simple, easy, and most importantly, totally controlled and versatile in contexts of both injury and full fitness, given that the user can configure the device to their liking at any time, changing the resistance force, the type of crimp, adjusting to the size of the hand, measuring the crimp path, working concentric and eccentric, etc... things that with the classics hold or die methods are not possible.



## WHAT ARE MUSKERS?

Muskers are simple magnetic devices (removable) that help us to indicate boulder routes we design for our indoor training. Muskers stay adhered to the holds we include in the route we have designed using powerful magnets.

Easier, quicker, more efficient and above all more playful. Muskers allow us, as we can say "pull it off at first try". These small devices made from soft and flexible silicone in different colours, allow us to design and mark climbing problems that we can repeat as much as we want without the typical memory problems, they also allow us to share routes with other climbers, without having to indicate one by one the holds to use.

Muskers are a practical personal removable system that allows us to mark routes on indoor boulders. They are pieces of silicone that on their lower end have an integrated powerful neodymium magnet shaped like a tablet that allows adhering the

piece to the screw joining the climbing hold to the panel. These screws are standard in the entire world, therefore Muskers can be used on any panel anywhere in the world.

Muskers come in enjoyable sets of 20 units. These sets have a metal base to facilitate storage of the Muskers adhered to the base of their case. Muskers can be chose from 4 different colours. Obviously, they are bright colours for perfect visualisation on a wall full of holds.

Thanks to the smooth, flexible but resistant silicone, we can place Muskers on any type of hold without hardly noticing the device under our hand. The flexible part of the device makes it adaptable to the shape of the hold and the powerful magnet sticks it to the hold so that it does not come loose not even with dynamic movements even if we apply much pressure on the Musker.

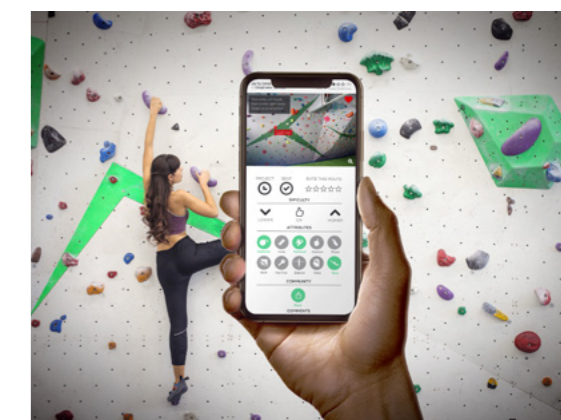
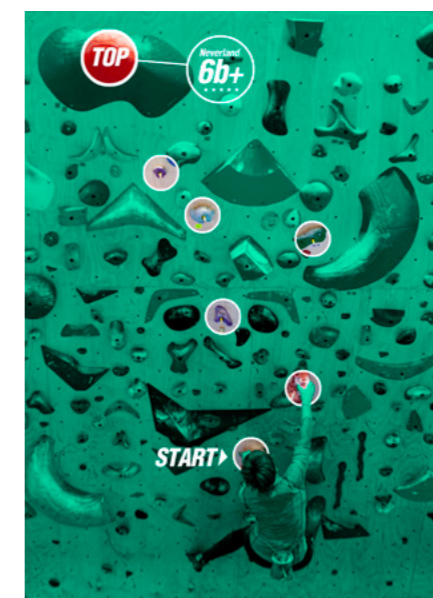
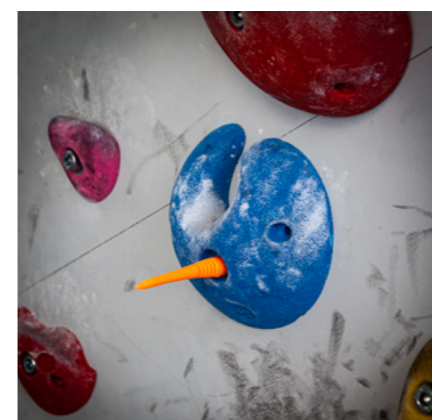

# CLIMBLAB

## CLEAN CLIMBING GYMS



Electrostatic filters for high-efficiency air cleaning

High-quality brushes with boar bristles made from FSC-sourced beech wood

Climblab's cleaning system improves efficiency by using EU crates

UltraGrip soap is biodegradable and made with health and safety in mind

Vacuum cleaner and hose optimized to work with Climblab's vacuum head

NEW

NEW

NEW

Climblab's vibrating vacuum head for more efficient cleaning

ChalkControl surface wash for reducing airborne chalk dust

## GONTAR



### Tenaya rental Shoe

- Reinforced rubber for greater durability.
- Adjustment capable of yielding where the foot needs it.
- Highly breathable tongue.
- Comfortable and easy fit.
- M4 technology improves performance without reducing comfort.
- Non marking rubber, optional.
- Sizes visible on the shoe pullers.
- Clip system to join the pair.
- Sizes 1 UK to 13 UK.



# OUR COMMITMENT TO CLIMBERS EVERYWHERE

In 1996, we established eGrips, now known as Trango Holds, in a nondescript garage in North Boulder. At that time, we were struggling with brittle, slippery Polyethylene holds (*PE*). Frustrated with the status quo, we made a daring choice: Polyurethane (*PU*), the same material used on nuclear submarine nose cones.

This groundbreaking innovation reshaped the climbing world, attracting a dedicated underground following. However, as a small team, keeping the dream alive was an uphill battle. The original holds, once revolutionary, ended up buried behind CATS Gymnastics under a trampoline—marking the quiet end of one chapter but the spark of something much bigger. In 2021 we embraced our history and rebranded everything Trango. To reflect our belief that every form of climbing matters and that our communities are diverse in the type of climbing they enjoy.

Trango's goal is to provide gear and holds for the ultimate climbing experience. By investing in innovation and expertise, we are shaping the future of climbing.

